

MTL Surge Technologies

Lightning & surge protection for fieldbus systems

Synopsis

This publication contains a brief introduction to fieldbus systems. It continues by describing the surge protection necessary to protect such systems from the detrimental effects of lightning and other surges.

Application Note TAN 1010

Application Notes from MTL Surge Technologies

MTL Surge Technologies publish an increasing number of Application Notes providing easily understood information on various aspects of lightning and surge protection. At the date of publication of this Application Note, the list included:-

- TAN1001** Lightning surge protection for electronic equipment – *a practical guide*
A relatively brief and easy to understand introduction to the subject – an excellent starting point.
- TAN1002** Lightning and surge protection – *basic principles*
A more detailed account of the mechanism of lightning strikes and the measures needed to achieve an adequate level of protection.
- TAN1003** Earthing guide for surge protection
A detailed analysis of the subject of earthing for surge suppression purposes, this is both an easily understood exposition and a valuable reference document.
- TAN1004** Surge protection for Intrinsically Safe systems
A description of the best methods of combining surge protection and Intrinsically Safe systems.
- TAN1005** Surge protection for Zone 0 locations
A detailed analysis of this particular aspect of surge suppression in hazardous areas; complements TAN1004.
- TAN1006** Surge protection for weighing systems
Discusses, in some detail, the application of surge suppression to load-cell weighing systems.
- TAN1007** Surge protection for Local Area Networks
Discusses ways in which Local Area Networks can be damaged by lightning induced transients and how they can be protected economically.
- TAN1009** Surge protection for electrical power installations
Discusses aspects of how to protect and install mains devices, with information on earthing and mains systems. A guide to simple maintenance techniques for surge protection devices is included.
- TAN1010** Lightning & surge protection for fieldbus systems
Discusses the major aspects of a fieldbus system and the surge protection required to ensure its smooth running and reliability.

About MTL Surge Technologies

MTL Surge Technologies, the surge protection division of the MTL Instruments Group plc, designs and manufactures a vast range of protection solutions for all your system surge protection requirements. Comprising of two leading surge protection brands, Telematic and Atlantic Scientific, MTL Surge Technologies has a combined experience of nearly 50 years within the surge protection industry.

The MTL Instruments Group has a strong and well respected presence within the Industrial Process market. This, combined with Telematic's close association with the Water Industry and Atlantic Scientific's presence in the Networks and Wireless Infrastructure market, means that MTL Surge Technologies is well placed to support a wide range of industries around the world.

MTL Surge Technologies supplies a comprehensive range of Telematic and Atlantic Scientific surge protection devices offering solutions for all mains power, process control, network and communications, telecom, wireless and RF systems.

Our commitment to not only meet but surpass our customers' high expectations can only be achieved by maintaining very high standards in all aspects of our business. Independent verification of our quality and safety procedures is of paramount importance and our accreditation to internationally recognised standards such as ISO 9001 is proof of this commitment. Our new 10 year 'no fuss' product warranty, is even further evidence of our confidence in our products and their application capabilities.

CONTENTS

PAGE

1	INTRODUCTION	1
2	FIELDBUS BACKGROUND	1
3	WHAT IS A SURGE PROTECTOR?	1
4	THE NEED FOR SURGE PROTECTION	2
5	MTL SURGE TECHNOLOGIES' SOLUTIONS FOR FIELDBUS SYSTEMS	2
5.1	Requirements.....	2
5.2	Power line protection.....	2
5.3	Fieldbus surge protection.....	2
5.3.1	Transmitter protection.....	2
5.3.2	Trunk protection.....	3
5.3.3	Impact of surge protection on the operation of Fieldbus.....	3
5.4	Fieldbus systems.....	3
5.4.1	Effective distance.....	3
5.4.2	Host protection.....	4
5.4.3	Field device protection.....	4
5.5	Use of the TP32-T to Terminate a Fieldbus Trunk.....	4
5.6	Hazardous area surge protection configurations.....	5
5.6.1	Zone 2/DIV 2 non-arcing/non incendive	5
5.6.2	Explosionproof/flameproof/increased safety	5
5.6.3	Intrinsically Safe system	5
6	STANDARDS	6
6.1	Surge protection related standards.....	6
6.2	Fieldbus related standards.....	7
7	FIELDBUS FREQUENTLY ASKED QUESTIONS	7
8	FIELDBUS GLOSSARY.....	7
9	APPENDICES	8
9.A	Appendix 1 - Number of fieldbus devices on a spur	8
9.B	Appendix 2 - Fieldbus cable lengths.....	8
9.C	Appendix 3 - TP32 thread information.....	8

1 INTRODUCTION

This application note discusses suitable surge protection techniques to protect electronic circuits and equipment within the fieldbus system and the associated fieldbus trunk from high voltages and surge currents induced by lightning and other forms of transients.

Most process control or telemetry installations are interconnected by power and signal cables and busses which run on trays, in ducting, underground or via overhead poles. Lightning strikes, static discharges and induction from power cabling are typical sources of transient voltages that can be coupled into signal cables and hence transmitted to electronic equipment. Field transmitters and computerised control equipment, etc. containing low-power semiconductor devices can be damaged by overvoltages of only tens of volts.

The longer the cables, the higher the magnitude of high voltage transients through shifts in earth potential, therefore devices controlling or monitoring events in remote locations are more likely to suffer from overvoltages and consequent component failures. Significant damage can also be found in equipment connected by relatively short cables if the circuits or components are particularly sensitive.

Electronic systems can be damaged or disrupted by what are referred to as "surges". These are voltages which are much greater than the normal working voltage and which appear in a system such as fieldbus for a short period of time, and hence are also sometimes referred to as "transient over-voltages". These surges can arise from switching of nearby heavy electrical equipment or from the clearance of an electrical short circuit fault (e.g. by a fuse blowing), but the most potent source is lightning.

It is important to appreciate that although catastrophic damage can indeed result from a direct lightning strike to a building, this is relatively rare. More usually is the substantial damage to electronic components inflicted by a strike to ground within a distance in the order of a kilometre or so. This can produce a surge on cables feeding vulnerable electronic equipment, resulting in damage. Typical damage to a circuit board consists of such items as scorched and vapourised copper track, burned and open-circuit resistors, integrated circuits with part of their package blown away, and semiconductor junctions failed short-circuit. At a lower level, there can be latent damage to semiconductors, which subsequently fail perhaps months later, as can happen with electrostatic discharges.

Surge protection consists of the use of hardware devices, increasingly termed surge protection devices (SPDs, see glossary for other terms), which, correctly positioned and installed, limit surge voltages reaching protected equipment to a safe level.

2 FIELDBUS BACKGROUND

Users of industrial process control systems are now able to specify proven and standardised fieldbus technology for their field instruments. Buses conveying both communication signal and power on the same pair of wires are among the most popular. An international standard physical layer used by Foundation Fieldbus and Profibus PA is specified by IEC 61158-2, (see section 6 of this document for further information).

A major influence on the economy of fieldbus installations is the number of field devices which can be connected on a single bus segment and hence to a single controller input/output (I/O) channel. In particular applications, users may choose to use only a small number of devices on a segment, in order to achieve faster scan cycles or for reasons of system integrity. In most cases, economic considerations lead to the desire to connect as many devices as possible on to a single cable and fieldbus port.

The IEC 61158-2 specification allows for up to 32 devices to be connected to the single pair of wires forming a bus segment (see Appendix 1, Table 1), most practical installations to date have between 6 and 12 bus-powered devices. There may be limitations depending on the design of the host system, but in practice, in IS (Intrinsically Safe) circuits the need to supply power to all of the devices limits the possible number of bus-powered devices on one segment.

DC voltage drop in the fieldbus cable reduces the supply voltage to the most remote devices (see Appendix 2, Table 2), and the situation requires greater consideration in Intrinsically Safe (IS) systems. Intrinsically Safe power supplies typically provide lower voltage and some versions include current-limiting resistors which contribute significantly to the voltage drop. Section 5 shows where careful selection of surge protection devices increases the availability of the fieldbus system and reduces / eliminates the adverse effects of surges.

3 WHAT IS A SURGE PROTECTOR?

Electronic equipment can be protected from the potentially destructive effects of high-voltage transients. Protective devices, known by a variety of names (including 'lightning barriers', 'surge arrestors', 'lightning protection units', etc.) are available. The 'correct' name (accepted internationally) is 'surge protection devices' or 'SPDs' – and this nomenclature is used throughout this publication.

Surge protection devices should ideally operate instantaneously to divert a surge current to earth, and control voltage to a level, which will not damage the connected equipment. Once the surge current has subsided, the SPD should automatically restore normal operation and reset to a state ready to receive the next surge.

MTL Surge Technologies specialise in the design and manufacture of SPDs. The range of products available includes models for virtually all applications. They are based on a combination of gas discharge tubes (GDTs), voltage-clamping diodes, and metal-oxide varistors (MOVs) which feature rapid operation, accurate voltage control and automatic resetting once the overvoltage has ceased.

The working voltage of a surge protection device is the normal working voltage of the application without affecting the circuit in which it is placed. It is also the maximum voltage between lines or from line to earth for the specified leakage current.

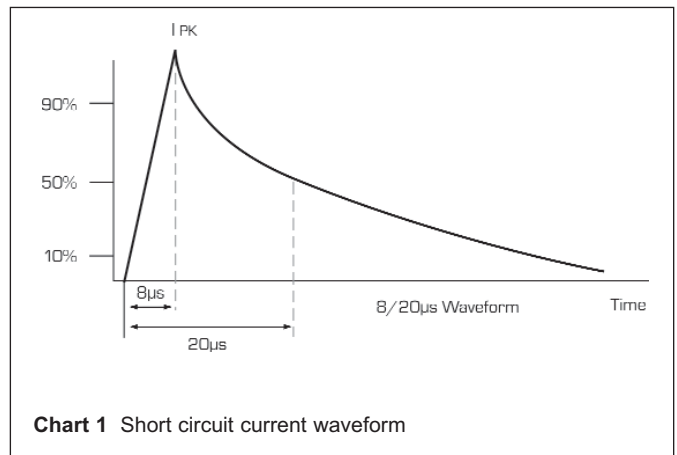

Limiting voltage is a measure of how good a surge protection device is at removing surges. Also known as '**Let-through Voltage**', this is the peak output voltage after injection of a test impulse from a 6kV/3kA 8/20µs combination waveform generator or some other specified voltage and current.

A good limiting voltage should be not much higher than the working voltage of the device. In general, however, it is usually around twice the working voltage

A correctly selected surge protection device should not change the characteristics or reliability of an application, whether it is for the protection of AC power systems, signal data systems such as fieldbus and 4-20mA, aerials (antennae) or telephony and communications systems.

The magnitude of lightning discharges around the world have been measured from 2kA to more than 200kA, with rise times to peak current of less than 10µs.

IEC 61024 gives the following data:–
1% of strokes exceed 200kA

10% of strokes exceed 80kA
50% of strokes exceed 28kA
90% of strokes exceed 8kA
99% of strokes exceed 3kA

4 THE NEED FOR SURGE PROTECTION

The fieldbus system by the very nature of the environment in which it will be placed, is at risk from surges that will be induced onto the trunk and AC or DC power supplies feeding the fieldbus system.

The units that can be affected include the controller and power supplies, the field devices, together with fieldbus terminators, spurs, expansion blocks and power conditioning modules.

Because the fieldbus system is controlling and handling the data transactions across a common trunk, the importance of safeguarding the integrity of the fieldbus system is paramount in order that the shutdown of multiple processes does not occur. This is particularly important in fieldbus process applications because of the possibility of injury to personnel and damage to process equipment and the environment. More information can be found in Section 5 on this topic.

If incorrect or inferior surge protection is fitted, then not only will the fieldbus sustain damage, but it could also cause the fieldbus to be affected adversely in that data communications is interrupted or the system is not able to support the required number of field instruments.

Considering these mechanisms in relation to process instrumentation, RFI rarely rises above the nuisance level.

Inductive effects require the close proximity of lightning currents to signal cables in order to achieve a measurable level of coupling. Generally, field signal cables are screened or shielded to reduce general RFI and noise pickup.

Twisted pair cables are normally used to reduce voltages between lines to levels that do not cause communication errors. However, shifts in earth potential will still be generated and can cause component damage in sensitive systems.

The 'host end' of any fieldbus system must have maximum protection to ensure full operation of the site, therefore protection must be installed on both AC and DC power and fieldbus cables.

The AC power for a fieldbus system could be supplied from the control area or locally in the field. In either case, surge protection is required at the fieldbus system.

In addition to the AC power, the fieldbus trunk must also be protected. If the two wire Trunk cable is longer than 50 metres in the horizontal plane or 10 metres in the vertical plane, for example, a sensor/transmitter is positioned on a column stack, pole or pipe, then the fieldbus must have surge protection.

When considering surge suppression of the local field wiring, the requirement is to look for more obvious situations such as:

- a) The spur cables connecting to a single instrument. Anything longer than 50 metres should be considered, longer than 100 metres must be protected.
- b) Particular installations where lightning currents would preferentially flow. For example instruments mounted along a pipeline which crosses a non-conducting surface such as dry sand.
- c) Installations that involve considerable vertical distances on structures that may be struck by lightning. A wind speed indicator on the top of a tall structure is a classic example.
- d) Installations where sensors are associated with high voltage, high power electrical equipment, For example temperature sensors embedded in the windings of high voltage motors.

Suitable protection devices should be used for hazardous and non-hazardous areas. The protectors should not cause any attenuation

and be of a mechanical design suitable for fitting to field devices.

In all cases, in a fieldbus installation, the trunk and the power supply to the nodes should be protected against lightning induced surges to provide reliability and system integrity. Local fieldbus field wiring to adjacent equipment where the length of the spurs are normally quite short is less prone to damage from surges but should be surveyed.

More information can be found in Section 5 on this topic.

5 MTL SURGE TECHNOLOGIES' SOLUTIONS FOR FIELDBUS SYSTEMS

5.1 Requirements

When considering the use of surge protection on a Fieldbus system, choice of the surge protection device, as well as its location in the system is critical. Inappropriate surge protectors can significantly degrade the Fieldbus signal limiting the maximum length of the system and or the number of devices that can be used.

5.2 Power line protection

AC power protection is often overlooked when deciding a surge protection strategy. When providing protection, users are keen to apply surge protection devices to process signal lines, transmitters and other important equipment, as the source of surges is more obvious. However, a common source of surges is the AC power supply. It is important to note that any cable entering an electronic device is also an easy path for lightning induced current to enter and cause untold damage, the power supply is no exception.

Any devices should be selected with appropriate regard to the physical location and be suitable for that purpose, especially with regard to the mounting of equipment in hazardous areas

Generally, most low voltage power systems (240/415V) and the electronic and electrical equipment with which they are associated, can withstand voltage surges of two to three times their normal peak operating voltage for the duration of a typical lightning surge.

During a lightning surge, the voltage is well in excess of these values and therefore surge protection is required.

5.3 Fieldbus surge protection

5.3.1 Transmitter protection

Transmitters can be located on parts of a plant that are exposed to full, or part of, the lightning currents; tall structures, pipelines, distillation columns are just a few examples. These are electrically severe environments where transmitters can be exposed to tens of thousands of volts and thousands of amps of surge current.

Protection options:

1. Surge components installed by the transmitter manufacturer ("the surge option").
2. Surge components built in to a distribution block where the spur joins the trunk.
3. Commercially available add-on surge.
4. A dedicated Fieldbus surge protector, thread mounted to the transmitter.

Selecting the surge option, provided by the transmitter manufacturer, typically adds a suppression diode into the transmitter. This device will fail at several hundred amps of surge current and certainly will not protect the transmitter during a nearby lightning strike.

Surge protection built into a distribution block is useful where the transmitter is physically close to that block. The further the transmitter is from the trunk the worse the protection level provided to the device. A tower-mounted transmitter, 10m from the trunk, will still be damaged during a lightning strike.

Much care is required if a commercially available surge protector is installed on Fieldbus. Many such devices have inline resistance and

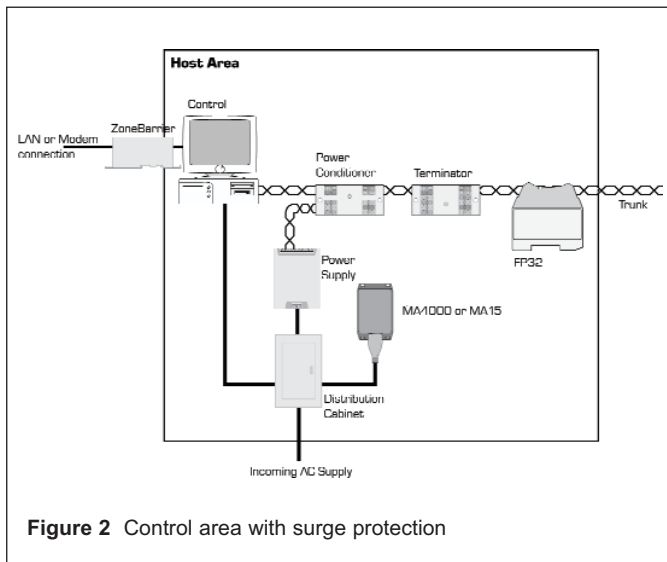

Figure 2 Control area with surge protection

5.4.2 Host protection

Figure 2 shows protection applied to the host. An SPD has been applied to the trunk and the power supply, due consideration should be given to any other communications from the control such as a modem or LAN. It would be the recommendation of this document that the trunk, if running outside of a building, should be protected at the host. This will prevent damage to the terminator, conditioner, fieldbus interface card and power supply from surges occurring in the field. Protection is also recommended as a matter of course on the AC power supply and any LAN/modem connection even in the event that the trunk cable does not run outside of the building. For field-mounted hosts' it is always recommended to provide protection.

5.4.3 Field device protection

The protection of field devices will depend on a number of factors; where the trunk length is 100m or greater, where devices are critical or difficult to replace and where devices produce a failure which would render the segment inoperable, in these instances a scheme of

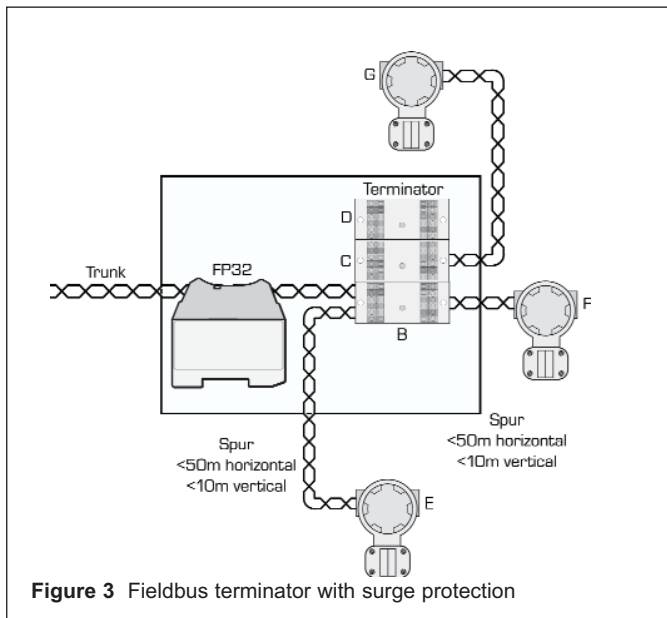

Figure 3 Fieldbus terminator with surge protection

implementing SPDs should be undertaken. Given these criteria, the effective distances should also be calculated as shown by the example in 5.4.1.

Figure 3 shows protection provided on the trunk. This would give adequate protection to the devices E, F and G and terminator if the surge is introduced from the host end of the trunk and the spur lengths are <50m horizontally or <10m vertically. If a spur length exceeds 50m then surge must be considered, if the spur exceeds 100m horizontally

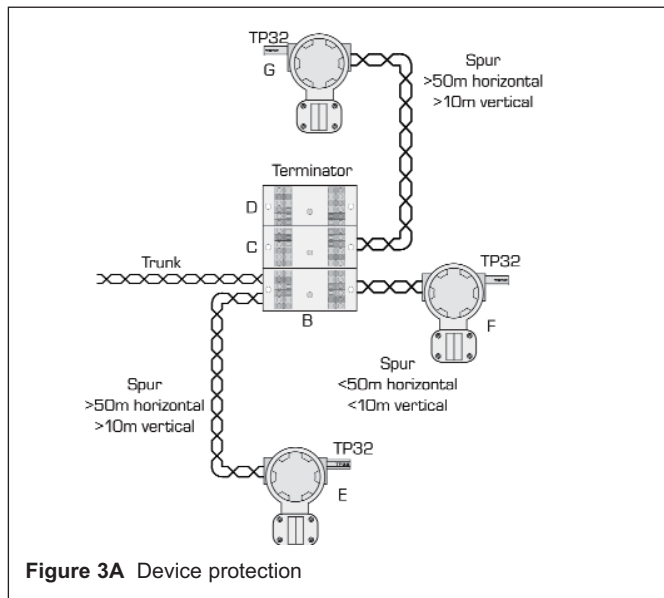

Figure 3A Device protection

or 10m vertically, then surge protection should be fitted to the field devices.

Figure 3A shows protection at the devices where the criteria for critical instruments or effective distance is calculated and shown to give a high risk of surge damage i.e. distance between E and G is >100m. This situation would also occur should the trunk be at or near its maximum length where the addition of surge protection at the distribution block would affect the performance of the bus

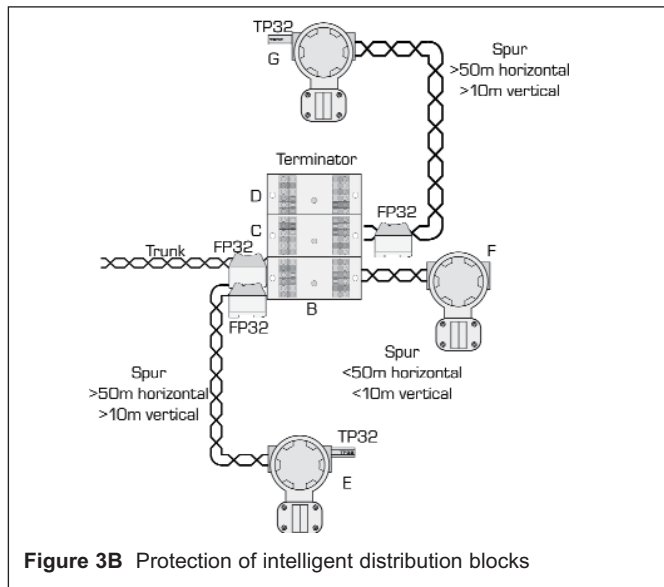

Figure 3B Protection of intelligent distribution blocks

communications. Device F would also require protection as the effective distance between the host and the devices is >100m.

Figure 3B shows a system where intelligent distribution blocks are used and where damage to these blocks would render the segment inoperable e.g. blocks containing short circuit protection. Protection has to be provided at both ends of the spur where the effective distance is above the figure recommended. Protection has also been implemented on the trunk to protect the integrity of the distribution block.

Figure 3C (next page) shows a system where several distribution blocks are used and the trunk cable is at, or near, its maximum length.

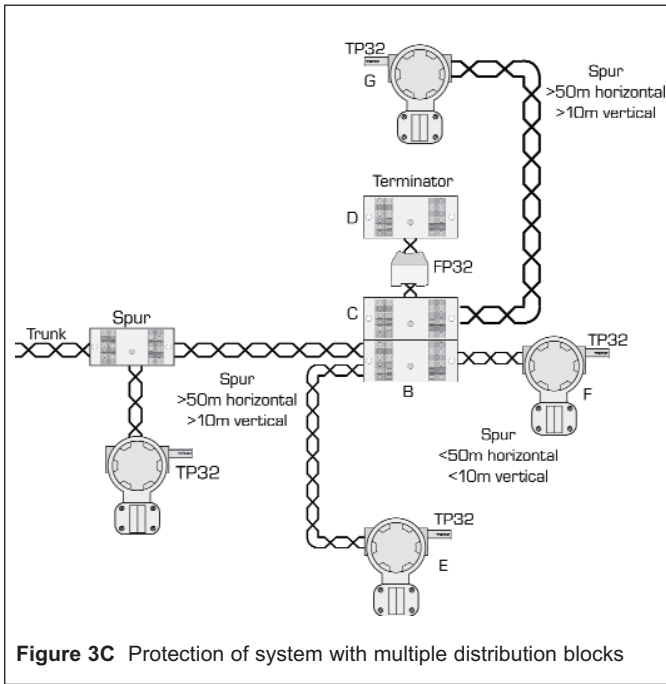

Figure 3C Protection of system with multiple distribution blocks

Protection is provided at the field devices and is the most effective solution. Protection can be provided for the terminator as shown since it does not affect the length of the fieldbus cabling.

5.5 Use the TP32-T to Terminate a Fieldbus trunk

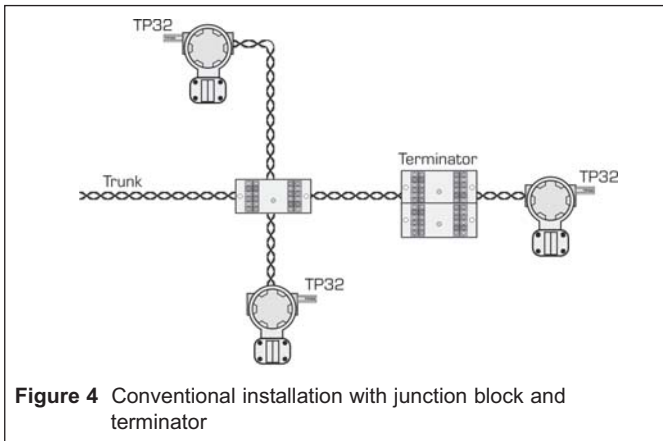

Figure 4 Conventional installation with junction block and terminator

Figure 4 (above) shows a conventional installation where a junction block and terminator are required at the far end of the Fieldbus trunk.

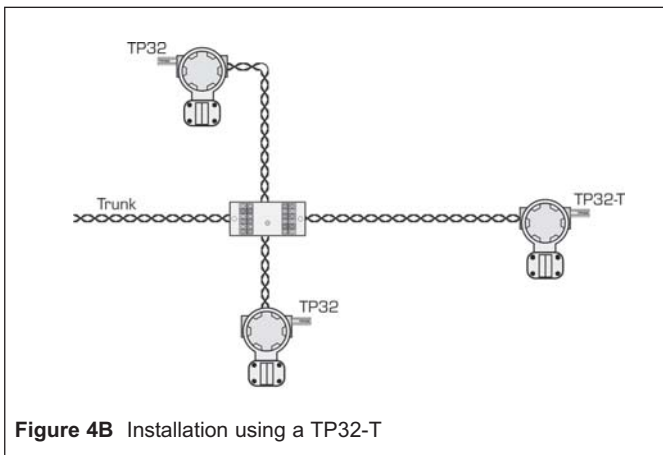

Figure 4B Installation using a TP32-T

Figure 4B (above) shows an installation using the TP32-T eliminating the need for an extra junction block and terminator.

The TP32-T offers an excellent alternative to typical Fieldbus terminators attached to a junction block. In some cases the TP32-T can save time and unnecessary terminal blocks as well as providing much needed surge protection.

5.6 Hazardous area surge protection configurations

5.6.1 Zone 2/DIV 2 Non Arcing / Non incandive

For non-arcing and non incandive applications, the unit that is suitable for

Zone 2 / Div 2 takes its description from the nature of the circuit being protected and is non incandive (nL) or non-arcing (nA), see figure 5.

Protection requirement:

Note: Protection at the host end of the Trunk is highly recommended.

- ◆ Use FP32 on Trunk at host end and TP32 at the field end terminator.
- ◆ Use FP32 on the input and output of the junction box to protect the power conditioner if remotely mounted and A-B (Fig 4) >100m.
- ◆ Use TP32-x, where x = thread type (see Appendix 3, Section 9.C) used on all transmitters with attached cables longer than 100 metres horizontal and 10 metres vertical as described in 5.4.3.
- ◆ Use the MA4000 or MA15 on AC power input at the host end and in the field mounted junction box.

In figure 5, next page, where the fieldbus controller is situated in the Zone/ DIV 2 area, a standard transmitter protector TP32 may be used without adversely affecting the level of safety.

Surge protection is required at the Control building both for the fieldbus trunk and the AC power. The field based unit must duplicate this protection with trunk surge protection both into and out of the fieldbus enclosure/junction box. The AC power may be obtained from a local power source or from the control area must also be protected from the likelihood of damage from induced surges from nearby lightning strikes. Depending on the length of the spur, the field instruments may also require transmitter protection even though they do not have any form of connection to earth. This is because the insulation voltage of a typical unit is in the order of 500 to 1500 volts. If a nearby lightning strike occurs, this value will easily be exceeded and damage will occur to the equipment due to internal arcing within the electronics of the unit.

5.6.2 Explosionproof / Flameproof / increased safety

For explosionproof / flameproof and increased safety in hazardous areas, suitable cables and junction boxes must be used (see figure 6).

Protection requirement:

Note: Protection at the host end of the Trunk is highly recommended.

- ◆ Use FP32 on Trunk at host end and TP32 at the field end terminator.
- ◆ Use TP32-x-NDI, where x = thread type (see Appendix 3, Section 9.C) used on all transmitters with attached cables longer than 100 metres horizontal and 10 metres vertical as described in 5.4.3.
- ◆ Use the MA4000 or MA15 on AC power input at the host end.

For transmitter protection, the surge protector must be certified to Ex d if not enclosed in a suitable Ex d enclosure. If the fieldbus controller is also mounted in a zone/division 1 hazardous area, it must also be housed within an Ex d enclosure as must the spur and termination fieldbus components.

5.6.3 Intrinsically Safe system

Intrinsic Safety (IS) is a protection concept employed in potentially explosive atmospheres. IS relies on the electrical apparatus being

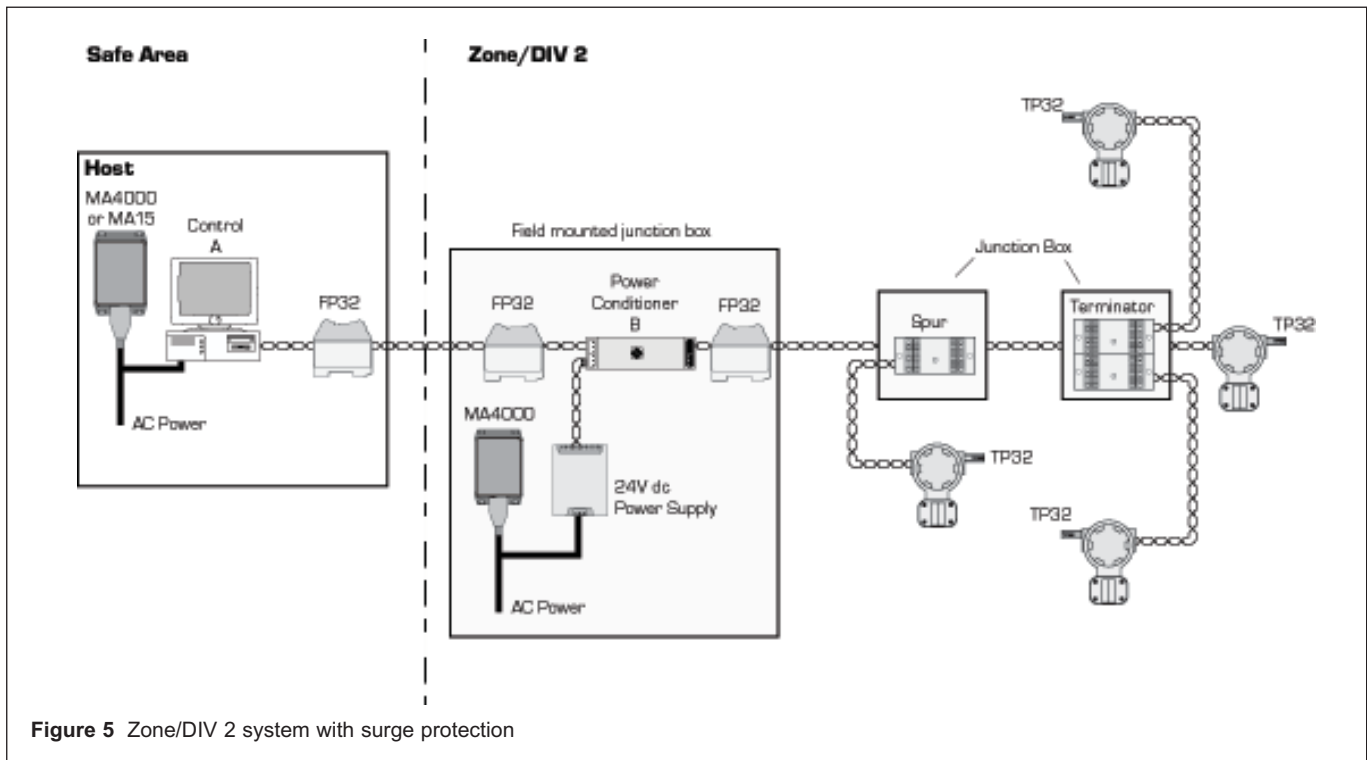

Figure 5 Zone/DIV 2 system with surge protection

designed so that it is unable to release sufficient energy, by either thermal or electrical means to cause an ignition of flammable gas or dust.

The Fieldbus FOUNDATION FF816 physical layer profile defines two IS physical layer profiles, entity and FISCO (Fieldbus Intrinsically Safe Concept). The SPDs should be certified to be compatible with both these profiles to allow flexibility in system installation.

Intrinsically Safe systems may be ia or ib. The surge protection is chosen in order that it does not affect the level of protection of the system (see figure 7).

Protection requirement:

Note: Protection at the host end of the Trunk is highly recommended.

- ◆ Use FP32 on Trunk at host end and at the input to the suitable enclosure.
- ◆ Use TP32-x-NDI, where x = thread type (see Appendix 3, Section 9.C) used on all transmitters with attached cables longer than 100 metres horizontal and 10 metres vertical as described in 5.4.3.
- ◆ Use the MA4000 or MA15 on AC power input at the host end and in the field mounted junction box.

The IS version of the TP32 Series is BASEEFA certified and may be supplied with various threads to suit the Transmitter glanding. If the TP32 version is not used, then the FP32 may be used, but must be installed within a suitable enclosure dependent upon the environmental conditions.

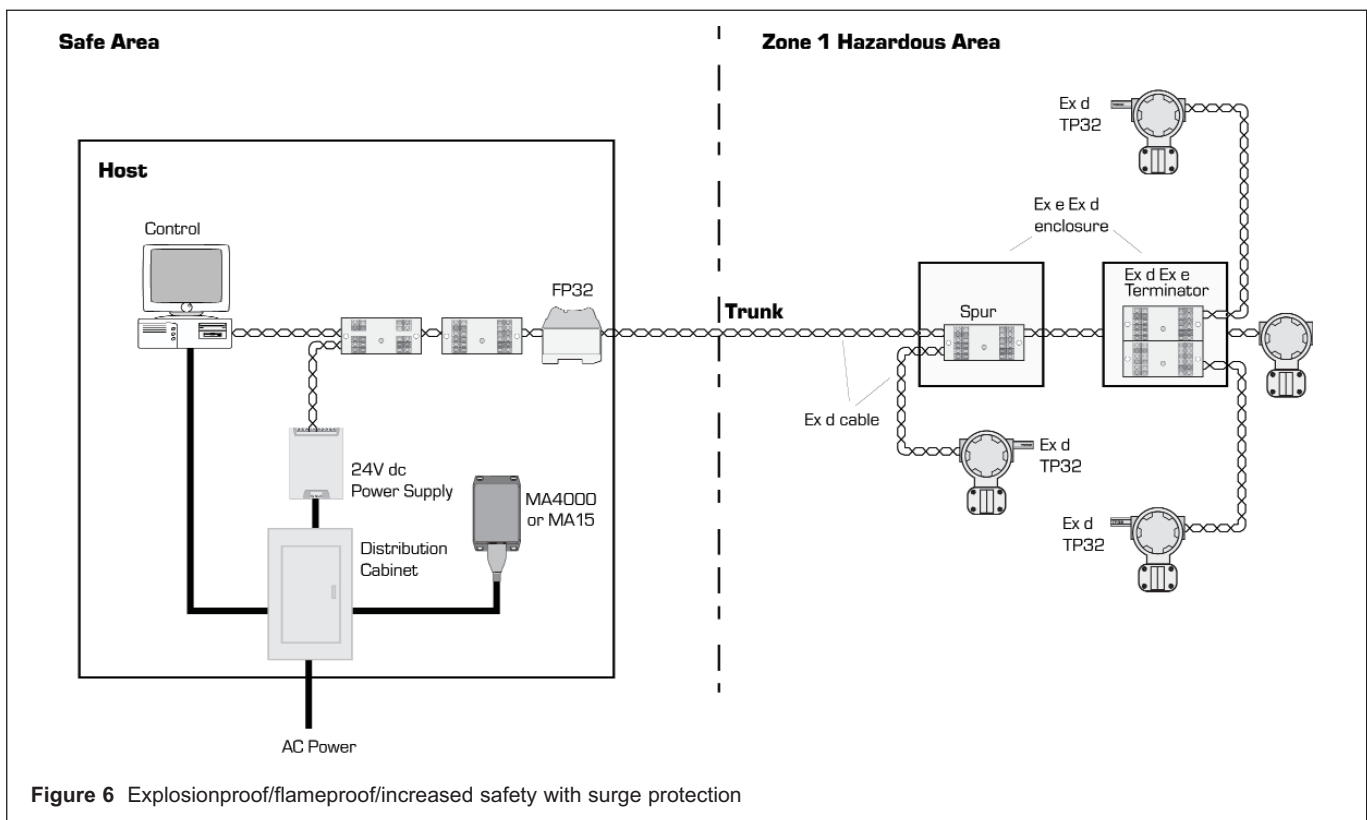

Figure 6 Explosionproof/flameproof/increased safety with surge protection

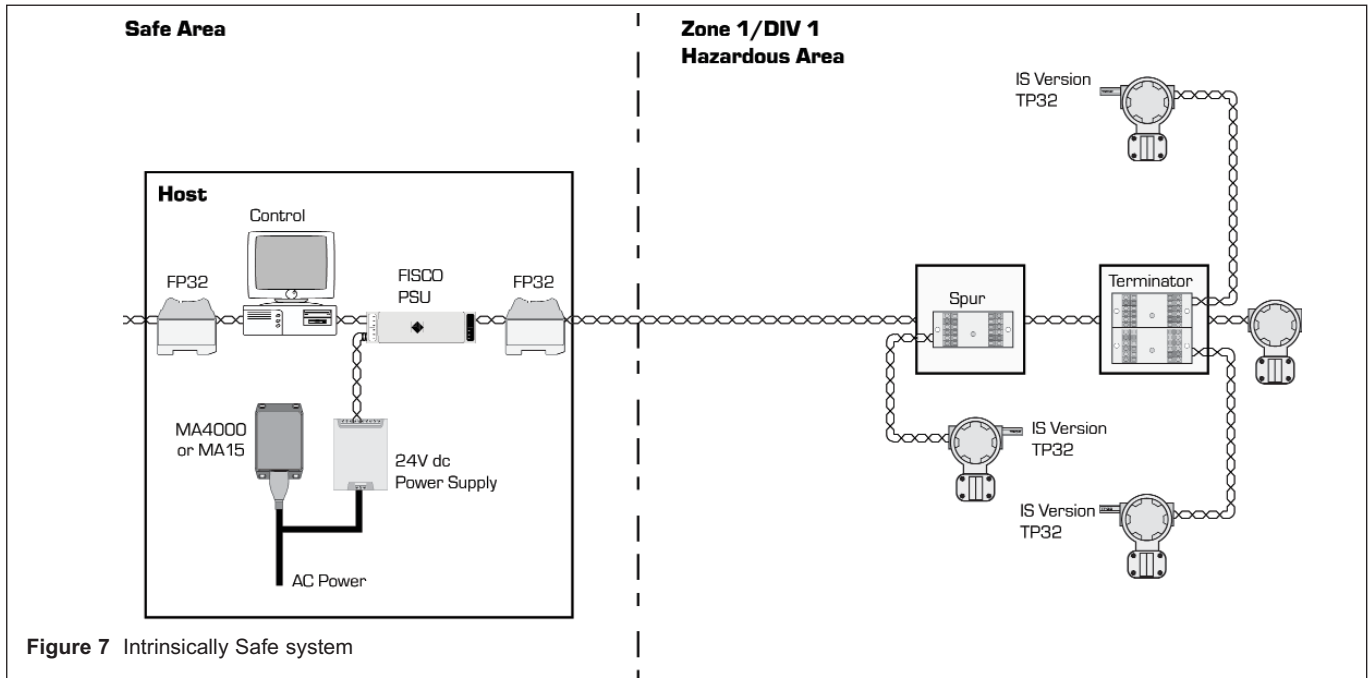

Figure 7 Intrinsically Safe system

6 STANDARDS

6.1 Surge protection related standards

BS 6651 Appendix C

Code of practice for protection of structures against lightning.

ANSI/IEEE C62.41-1991

ANSI/IEEE Recommended Practice on Surge Voltages in Low-Voltage AC power circuits.

IEC 61000-4-5 – Electromagnetic compatibility (EMC) Part 4.

Testing and measurement techniques. Section 4. Electrical fast transient/burst immunity test - Basic EMC publication.

IEC/EN 60079-14 : 1997

Electrical apparatus for explosive gas atmospheres, Part 14. Electrical installations in hazardous areas (other than mines).

IEC 61024

Protection of structures against lightning, Part 1. General principles, section 1 : Guide A : selection of protection levels for lightning protection systems.

6.2 Fieldbus related standards

IEC 61158-2 : 1996

Fieldbus standard for use in industrial control systems - Part 2. Physical layer specification and service definition, amendment number 2.

CENELEC EN 50170

General purpose field communication systems EuroNorm EN 50170.

7 FIELDBUS FREQUENTLY ASKED QUESTIONS

We have never had any problems with surges, why do I need protection?

Lightning is not the only source of problematic surges. Have you ever measured or analysed incidents of lightning/voltage transient? Do you suffer unexplained or spurious failures rather than immediate failures? Electronic systems can suffer from long term gradual failures as a result of surge induced stress.

We don't get lightning here so we should not have a problem...

Does not need to be a local strike (can be up to 1Km away).
Lightning is not the only source of surges.
Does not need to be a direct strike.

Geographical lightning authenticity charts will indicate local incidence levels

Some of my equipment is inside a building, why do I need protection?

Protection for fieldbus systems needs installing on all cables carrying the following supply to and from the building

- ◆ Data
- ◆ Mains power
- ◆ Fieldbus trunks
- ◆ Fieldbus spurs that are longer than 50 metres

All of my I/O has isolation, why do I need protection?

Isolation is good up to a point/at a level (say 8-10kV) it is prone to breakdown.

Lightning generated voltages can run to 100's of kV.

Lose your isolation you've lost all or part of your fieldbus system.

The SPD's are more expensive than the equipment they are protecting, why should I bother to protect?

When deciding the cost of surge protection devices there are several things to take into consideration.

Safety aspects of plant and personnel.

How much does it cost to shut down an entire fieldbus system for a day?

How much business can you afford to lose if your computer system fails?

Surge protection devices can make your installation more reliable and you need to look at the whole cost not just the equipment cost.

Maintenance/service costs can be expensive and can mean extensive system downtime.

We have IS systems which do not allow an earth point in the hazardous area, and your SPD's need to be earthed at both ends of the loop, how can I use surge protection?

SPD's utilise earth connection in the event of a strike and are isolated from earth at other times. This point is clarified in MTL documentation and considered in the relevant code of practice IEC/EN 60079-14.

8 FIELDBUS GLOSSARY

Attenuation	Signal getting smaller as it travels on the cable
Cable	A number of wires and shielding in a single sheath
Daisy-chain	A wiring method where a number of devices are attached along the trunk cable
Device	A sensor, actuator or control equipment attached to the fieldbus
Fieldbus	A process control local area network defined by ISA standard SP50.02
Frame	A single transmission from a device
H1	The 31.25 kbit/second type of fieldbus
Intrinsic Safety	A low energy protection technique that cannot cause an explosive atmospheres to ignite.
Reflection	An unwanted signal that results from a cable fault or improper termination
Segment	A part of a fieldbus network wiring that is electrically independent from other parts
Surge	A large unwanted voltage or current on wires generally caused by lightning or nearby heavy electrical power use
Surge Protection Device (SPD)	A device used to discharge surges to the earth/ground
Terminator	A device used to correctly terminate at the end of a wire thus minimising reflections deal. Some existing cable may be very good while other cable of the same type may be waterlogged, have deteriorated insulation or be mechanically damaged. The only real way to determine if existing cable is suitable for fieldbus or if new cable has been installed correctly is to use a fieldbus tester.

The fieldbus standard contains estimates of how long a fieldbus cable can be and still get adequate signal quality. For the standard fieldbus cable, and some types of existing cables used for control applications, the limits are:

9 APPENDICES

9.A Appendix 1 - Number of fieldbus devices on a spur

Table 1 Number of fieldbus devices on a spur

Number of Devices on segment	Maximum total spur length with one device on spur
1-12	120 metres
13-14	90 metres
15-18	60 metres
19-24	30 metres
25-32	No spurs allowed, devices must be attached directly to the home run cable

These are only estimates. The quality of existing cable may vary a great deal. Some existing cable may be very good while other cable of the same type may be waterlogged, have deteriorated insulation or be mechanically damaged. The only real way to determine if existing cable is suitable for fieldbus or if new cable has been installed correctly is to use a fieldbus tester.

9.B Appendix 2 - Fieldbus cable lengths

The fieldbus standard contains estimates of how long a fieldbus cable can be and still get adequate signal quality. For the standard fieldbus cable, and some types of existing cables used for control applications, the limits are:

Cable type	Distance (metres/feet)	Characteristic Impedance (Ohms)	Resistance (Ohms/Km)	Atten. (DB/Km)	Description
Type A	1900/6270	100	22	3	Each twisted pair has shield
Type B	1200/3960	100	56	5	Multiple twisted pairs with overall shield
Type C	400/1320	Unknown	132	8	Multiple twisted pairs, no shield
Type D	200/660	Unknown	20	8	Multiple conductor cable, no pairing of wires

Table 2 Fieldbus cable length standard

9.C Appendix 3 - TP32 thread information

The following thread types and sizes are available:

- ◆ N = 1/2 inch NPT
- ◆ I = 20mm ISO
- ◆ G = G 1/2 inch (BSP 1/2 inch)

MTL Surge Technologies.... Protecting Investments Worldwide

For further information contact your local MTL office or visit
www.mtlsurge.com

Europe, Middle East & Africa

The MTL Instruments Group plc Measurement Technology Limited

Escapeline Limited
Power Court, Luton, Bedfordshire
England LU1 3JJ
Tel: +44 (0)1582 723633 Fax: +44 (0)1582 422283
Email: enquiry@mtl-inst.com

MTL Instruments sarl

Les Carrés du Parc
10 rue des Rosiéristes
69410 Champagne au Mont d'Or
France
Tel: +33 (0)4 78 64 98 32 Fax: +33 (0)4 78 35 79 41
Email: info@mtl-inst.fr

MTL Instruments GmbH

An der Gumpgesbrücke 17, D-41564 Kaarst,
Germany
Tel: +49 (0)2131 718930
Fax: +49 (0)2131 7189333
Email: info@mtl.de

MTL Italia srl

Via Cantù 11, 1-20092 Cinisello Balsamo
MI, Italy
Tel: +39 (0)2 61802011 Fax: +39 (0)2 61294560
Email: info@mtl-inst.it

MTL Instruments BV

de Houtakker 33, 6681 CW Bommel, The
Netherlands
Tel: +31 (0)481 450250 Fax: +31 (0)481 450260
Email: info@mtlbenelux.com

MTL Instruments

Abu Dhabi Mall, The Towers at the Trade Centre
West Wing - 8th Floor
PO Box 53234, Abu Dhabi, UAE
Tel: +971 2 645 2620 Fax: +971 2 645 2630
Email: mtlgulf@mtl-inst.com

The Americas

MTL Incorporated

9 Merrill Industrial Drive,
Hampton, NH 03842, USA
Tel: +1 800 835 7075, +1 603 926 0090
Fax: +1 603 926 1899
Email: info@mtlinh.com

MTL Canada Safety Instrumentation

#102, 4249 97 Street
Edmonton, Alberta
Canada T6E 5Y7
Tel: +1 780 485 3132
Fax: +1 780 485 3122
Email: info@mtlinh.com

Asia

MTL Instruments Pte Limited

31 Ubi Road
#04-01 Aztech Building
Singapore 408694
Tel: +65 6 487 7887 Fax: +65 6 487 7997
Email: sales@mtlsing.com.sg

MTL Instruments KK

3rd Floor, Gotanda Masujima Building,
1-8-13 Higashi-Gotanda, Shinagawa-Ku,
Tokyo 141-0022, Japan
Tel: +81 (0)3 5420 1281 Fax: +81 (0)3 5420 2405
Email: sales@mtlkk.co.jp

MTL Instruments Pty Limited

1/30 Canvale Road
Canning Vale, Perth,
WA 6155, Australia
Tel: +61 (0)8 9455 2994 Fax: +61 (0)8 9455 2805
Email: enquiries@mtlaus.com.au

MTL Instruments Pte Limited

Room 1002A, The Gateway,
No. 10 Yaobao Road, Chaoyang District,
Beijing, 100020 People's Republic of China
Tel: +86 10 65915718/20/21
Fax: +86 10 65915725
Email: bjsales@mtl-inst.cn

MTL India Pvt Limited

No. 36, Nehru Street,
Off Old Mahabalipuram Road,
Sholinganallur
Chennai - 600 119
India
Tel: +91 (0)44 2450 1660/2450 1857
Fax: +91 (0)44 2450 1463
Email: sales@mtlindia.com

MTL Surge Technologies

Power Court, Luton, Bedfordshire, England LU1 3JJ
Tel: +44 (0)1582 723633 Fax: +44 (0)1582 422283
E-mail: enquiry@mtlsurge.com WWW: www.mtlsurge.com

A member of the MTL Instruments Group plc

