

MTL Surge Technologies

Surge protection for weighing systems - an application guide

Synopsis

This publication discusses the nature of modern weighing systems and describes the various methods by which surge protection can be applied to load cells (digital and conventional), to control systems, etc, within the weigh cabin and to external system links.

Application Note
TAN 1006

Application Notes from MTL Surge Technologies

MTL Surge Technologies publish an increasing number of Application Notes providing easily understood information on various aspects of lightning and surge protection. At the date of publication of this Application Note, the list included:–

- TAN1001** Lightning surge protection for electronic equipment – *a practical guide*
A relatively brief and easy to understand introduction to the subject – an excellent starting point.
- TAN1002** Lightning and surge protection – *basic principles*
A more detailed account of the mechanism of lightning strikes and the measures needed to achieve an adequate level of protection.
- TAN1003** Earthing guide for surge protection
A detailed analysis of the subject of earthing for surge suppression purposes, this is both an easily understood exposition and a valuable reference document.
- TAN1004** Surge protection for intrinsically safe systems
A description of the best methods of combining surge protection and intrinsically safe systems.
- TAN1005** Surge protection for Zone 0 locations
A detailed analysis of this particular aspect of surge suppression in hazardous areas; complements TAN1004.
- TAN1006** Surge protection for weighing systems
Discusses, in some detail, the application of surge suppression to load-cell weighing systems.
- TAN1007** Surge protection for Local Area Networks
Discusses ways in which Local Area Networks can be damaged by lightning induced transients and how they can be protected economically.
- TAN1009** Surge protection for electrical power installations
Discusses aspects of how to protect and install mains devices, with information on earthing and mains systems. A guide to simple maintenance techniques for surge protection devices is included.
- TAN1010** Lightning & surge protection for fieldbus systems
Discusses the major aspects of a fieldbus system and the surge protection required to ensure its smooth running and reliability.

About MTL Surge Technologies

MTL Surge Technologies, the surge protection division of the MTL Instruments Group Plc, designs and manufactures a vast range of protection solutions for all your system surge protection requirements. Comprised of two independent but closely linked companies, Telematic and Atlantic Scientific Corporation, MTL Surge Technologies has a combined experience of nearly 50 years within the surge protection industry.

The MTL Instruments Group has a strong and well respected presence within the Industrial Process market. This, combined with Telematic's close association with the Water Industry and Atlantic Scientific's presence in the Networks and Wireless Infrastructure market, means that MTL Surge Technologies is well placed to support a wide range of industries around the world.

MTL Surge Technologies supplies a comprehensive range of Telematic and Atlantic Scientific surge protection devices offering solutions for all mains power, process control, network and communications, telecom, wireless and RF systems.

Our commitment to not only meet but surpass our customers' high expectations can only be achieved by maintaining very high standards in all aspects of our business. Independent verification of our quality and safety procedures is of paramount importance and our accreditation to internationally recognised standards such as ISO 9001 is proof of this commitment. Our new 10 year 'no fuss' product warranty is even further evidence of our confidence in our products and their application capabilities.

CONTENTS

PAGE

1	INTRODUCTION	1
	1.1 General	1
	1.2 Surge protection for weighing systems.....	1
2	WEIGHING SYSTEMS AND LOAD CELLS	1
	2.1 Load cells	1
3	SURGE PROTECTION FOR WEIGHING SYSTEMS	1
	3.1 Load cells and lightning and/or surge damage	1
	3.2 Surge protection components and devices	2
	3.3 Accuracy considerations	2
4	WEIGHING SYSTEMS – SURGE PROTECTION CONNECTIONS.....	4
	4.1 Line connections	4
	4.2 Earthing	4
5	MISCELLANEOUS ASPECTS	5
	5.1 Hazardous-area applications	5
	5.2 Digital load cells	5
	5.3 Overall systems considerations	6
	5.4 Legal Metrology	6

SURGE PROTECTION FOR WEIGHING SYSTEMS – AN APPLICATION GUIDE

1 INTRODUCTION

1.1 General

Modern weighing systems rely on high performance electronic components. These are becoming increasingly smaller and cheaper so modern weighing systems can provide ever faster operation combined with decreasing power consumption. There is, however, a disadvantage. Smaller components are less able to dissipate significant impressed currents than their predecessors and are thus more vulnerable to the damaging effects of induced overvoltages and surge currents. The need for surge protection is apparent.

1.2 Surge protection for weighing systems

Conventional weighing systems are particularly difficult to protect because system performance is immediately degraded by the addition of standard surge protection devices (SPDs). Any significant series impedance affects the calibration and surge diodes are prone to leakage. Many installers offer ineffective protection based on simple gas-discharge tubes (GDTs). These divert large currents once fired but have a high limiting voltage during the firing process.

With the help of consultations with manufacturers of weighing transducers, Telematic's LC30 surge protection device is designed to overcome these problems by taking into account the specific needs of weighing systems. The LC30 provides a full hybrid circuit capable of repeatedly diverting large (10kA) surges and controlling limiting voltages at low levels without imposing more than 1W series impedance.

Weighing systems are making increasing use of digital cells as the way forward. These have the advantage that analogue-to-digital conversion at the sensor greatly reduces the possibility of on-site errors, thereby improving system reliability. Surge protection is, of course, also needed for these and the LC30 SPD is again, the favoured choice.

Weighing systems are frequently connected to plant-wide information networks. Any such data link is susceptible to induced transients at either end or both. Power cables, telephones and modems are all potential sources and/or victims of such transients so all should be protected by suitable SPDs.

2 WEIGHING SYSTEMS AND LOAD CELLS

2.1 Load cells

Load cells are the primary sensors used by modern weighing systems. In these, highly sensitive etched foil strain-gauges are bonded onto high tensile alloy steel billets (see figure 1). When the load cell is subjected to loading, the strain-gauge registers a change in resistance which is used, with a suitable measuring system, to provide accurate, sensitive and repeatable indications of load. Typically, several strain-gauges are used in each load cell (to provide a balanced bridge network) together with temperature compensation and span-setting resistance elements. All components are bonded to the steel billet with a suitable epoxy resin.

Electrically, the load cell is equivalent to a bridge network which, when energized by a supply (excitation) voltage, returns a voltage directly proportional to the applied load (see figure 2). The power supplied to the load cell is minimized to prevent self-heating of the strain-gauge element which would clearly affect system accuracy adversely. Load cell sensitivity is normally expressed as a mV output per V excitation at full rated load. For example, if a 1000 ton 2mV/V cell is used with a 20V supply, a 10mV signal represents a 250 ton loading. As in this example, the relationship between loading and output voltage is linear as long as the cell is operated within its rating and the system as a whole is calibrated to take account of static loading or tare weight.

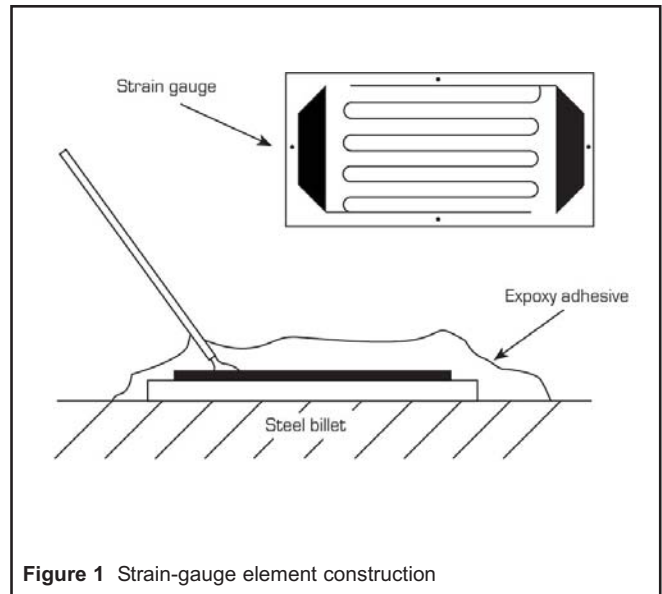

Figure 1 Strain-gauge element construction

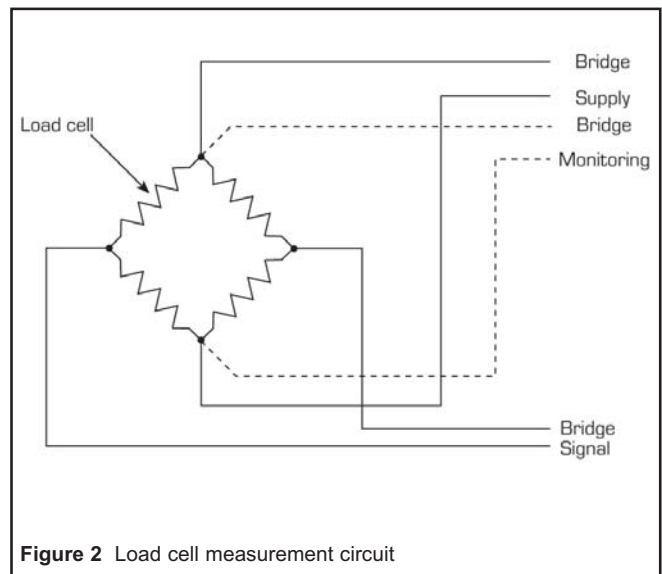

Figure 2 Load cell measurement circuit

Any variation in resistance of the supply leads to the cell will similarly affect the measurement, so where best accuracy is needed, 6-wire (2-wire supply, 2-wire signal and 2-wire supply monitoring) connections are used. The devices themselves can operate on dc or ac supplies depending upon the system design.

3 SURGE PROTECTION FOR WEIGHING SYSTEMS

3.1 Load cells and lightning and/or surge damage

Load cells are usually built-in to some kind of weighing system such as a weigh bridge, process weighing silo or other installation. Generally, lightning will strike the highest object in a given area so large installations may need to act as their own lightning conductors. Non-metallic installations, such as concrete grain silos, should have copper down conductors and earth mats to protect the fabric of the building. Metallic structures, on the other hand, are usually expected to be capable of carrying lightning currents (without damage) through their casual bonds – which may be augmented by dedicated bonding conductors to protect particularly sensitive or exposed areas. Lightning currents will, in any event, find their way to physical ground by whatever conductive path proves most convenient (trees, people, etc). However, the act of hitting the ground and dissipating into the earth is not the end of the story, particularly where cable-connected systems are distributed round a process plant.

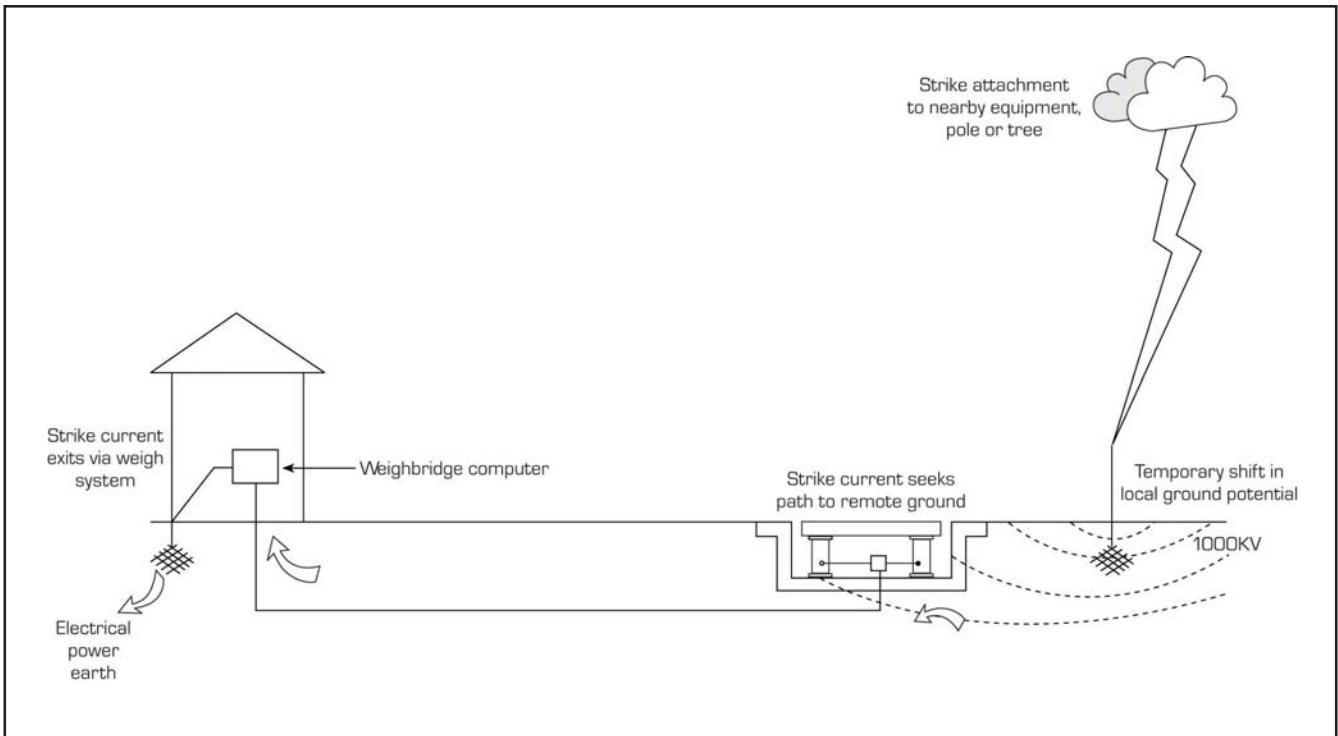

Figure 3 Weigh system damage caused by resistive coupling following a breakdown under local high voltage

The injection of any current into a resistance generates a voltage gradient. Lightning currents are very large (10 to 200kA peak/stroke) and the resistance of even a purpose-built earth mat is finite (typically 2 to 10Ω). Very large transient voltages are therefore generated in the immediate vicinity of any lightning impact. This is only a problem for conductors, of whatever quality (people, livestock, electrical circuits, etc.) that may be straddling that particular potential gradient. A weighing system may therefore be exposed to very high voltage differentials between the weigh bridge or silo and the earth connection in the weighing cabin or control room due to lightning strikes close to either end of the circuit or even to nearby structures (see figure 3). The main culprit is the connecting cable – if all the weighing system is at one point, no differential voltages can be generated and no damage caused (always assuming, of course, that power cables to the system from elsewhere are protected!). Unfortunately, the longer the cables, the greater the exposure to possible transients – and it makes little difference whether the cables are buried, shielded or slung overhead.

Modern load cells depend upon stable bonding of the strain gauges to the steel billet. Voltage surges can affect this bonding seriously. In practice, several strain gauges and compensating resistors are connected together, the maximum voltage the combination can tolerate being usually 400 to 500V before the epoxy resin adhesive begins to delaminate. Even though damage may only affect one or two strain gauges, the usual result is an unacceptable scale drift and/or an inability to reset to zero. In any event, the damage is usually irreparable and the load cell must be replaced – an operation which may also call for a complete re-calibration of the weighing system.

3.2 Surge protection components and devices

Protection components are either capable of diverting large currents, limiting excess voltages and/or (sometimes) absorbing energy. Since no single type of component successfully provides all three functions, hybrid protection networks are usually designed round combinations of appropriate components.

3.2.1 Gas-filled discharge tubes

The gas-filled discharge tube (GDT) is the classic device for large current diversion and can handle currents up to 20kA in conventional packages. It is basically a sealed spark-gap in which some control over firing is exercised by the specific physical dimensions and gas filling of the device. However, the process of forming an arc within a

GDT takes time and a fast rising transient such as lightning will cause significant overshoot – a standard 260V GDT will ‘let-through’ 700-1000V under 1kV/ns rise-time impulses. GDTs alone are therefore not suitable for protecting sensitive equipment.

3.2.2 Zener diodes

Zener diodes are well known for their ability to limit voltages and for their consistent failure under load currents slightly over nominal ratings. The larger the P/N junction, the more able is a Zener diode to tolerate short term overcurrents, but even the most able will fail through overheating under steady-state overload conditions. The value of a Zener diode lies therefore in its ability to ‘clamp’ an overvoltage in the initial stage of a surge before another component, such as a GDT, takes over.

3.2.3 Metal oxide varistors

Metal oxide varistors (MOVs) work by allowing surge currents to flow throughout the body of the material rather than a small junction area and so are often used where energy absorption is required. However, each internal microscopic junction also contributes to a leakage current across the component so MOVs are limited to ac/dc power supply protection or other applications where leakage currents of a mA or so are acceptable. In service, MOV micro-junctions tend to fuse together with each impulse until eventually the MOV self-destructs by short-circuiting.

3.2.4 Hybrid circuits

In practice, effective SPDs make use of hybrid circuits incorporating more than one type of component - so using, for example, the immediate response of a Zener (or ‘surge’) diode to cancel out the relatively slow response of a GDT until the spark-gap firing action of the latter ‘takes over’ and prevents the diode overheating. Combinations of this type are chosen with appropriate ratings to suit individual applications.

3.3 Accuracy considerations

Weighing systems for commercial use are usually tested to demonstrate the accuracy of their performance under varying temperature conditions. The graphs reproduced in figure 4 are the results of typical temperature tests made to OIML R60-1991 specifications and in which the overall system inaccuracy must remain within the specific envelope. The test profile allows for temperature stabilization, preload, load, creep and recovery measurements of the system, repeated at four temperatures which, in sequence, are: +20°C, 10°C, +40°C and +20°C.

Graph 4a is a test profile for a system which does not include an LC30 SPD and graph 4b the same system with an LC30 added. Graph 4b indicates that adding the LC30 makes only minor shifts in Zero Load output and sensitivity and that a successful installation can be made to R60 Accuracy Class C3. The minor change caused by the inclusion of the LC30 together with the temperature stability demonstrated allows for simple re-calibration with no effect on overall accuracy.

The LC30 is designed for insertion into conventional analogue weighing systems with minimal effect on measurement accuracy – as is borne out by graph 4b. It is connected in series with the signal, excitation and sense lines and imposes only 1W series resistance per line, which is barely detectable as a shift in span. In operation, incoming transients are clamped immediately without causing leakage errors under normal conditions and – once the transient has passed – it automatically resets to the passive state, allowing normal operations to continue.

Digital load cells are inherently less sensitive to devices inserted into the connecting cabling. Once the A/D conversion process has provided a word of appropriate length for the required resolution, all that is normally needed is sufficient power to transmit that data back to the receiver.

The LC30 works just as well with either digital load cells or with analogue cells. See section 4 for connection details for systems incorporating both types of cells.

For digital data links, Telematic and Atlantic Scientific also manufacture other devices for use with twisted-pair or co-axial cables.

4 WEIGHING SYSTEMS – SURGE PROTECTION CONNECTIONS

4.1 Line connections

Both ends of a weighing system, i.e. both the load cell and the receiving equipment in the weigh cabin should be protected, as the protection from a single SPD only operates locally. Figures 5 and 6 illustrate load cell connections and figure 7 shows a weigh cabin connection.

4.1.1 Load cell connections - systems with field junction boxes

Most weighing systems with multiple load cells use field junction/summation boxes (JBs) to combine signals and also as a convenient point for line balancing or corner correction. For these systems, one field-mounted LC30 SPD should be installed close to the JB in the common cable wired back to the weigh cabin (as shown in figure 5).

4.1.2 Load cell connections - systems with multiple connections

Where systems design requires multiple load cell signals to be separately wired back to the weigh cabin for individual connection to the weighing signal processor, individual SPDs are needed for each line as shown in figure 6.

4.2 Earthing

Correct earthing is essential for successful protection. The essence of

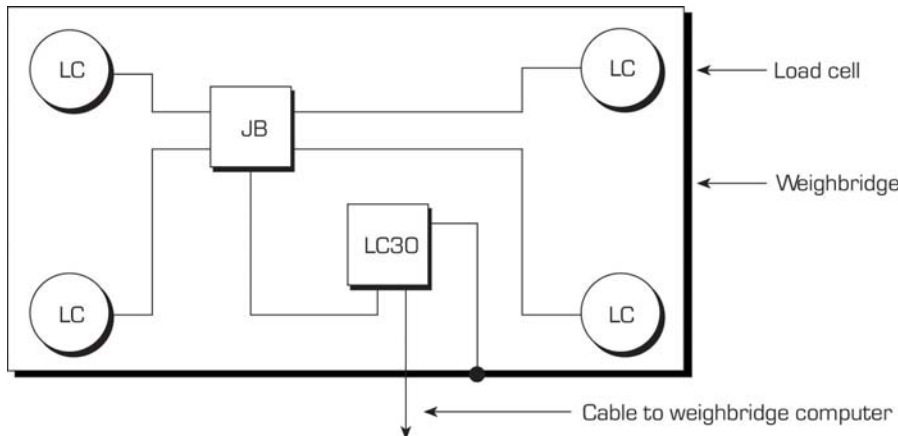

Figure 5 Weighbridge with field junction

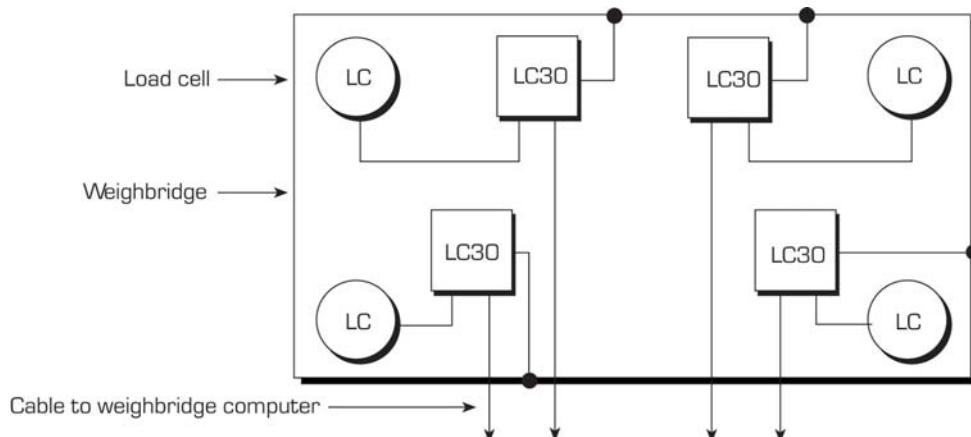

Figure 6 Weighbridge with individual load cell connections

protection for electronic/electrical equipment is a minimal potential difference between the circuit and local earth. Any device which operates by diverting large currents to earth must have a low impedance connection to that earth. Thus, the bonding connection(s) must be of low resistance

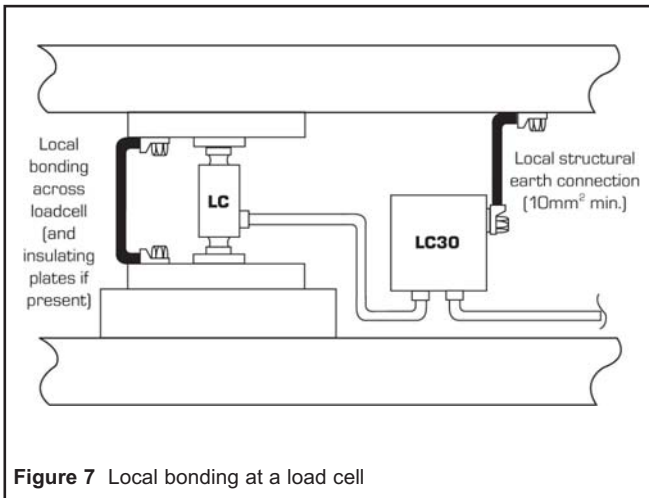

Figure 7 Local bonding at a load cell

and capable of carrying large currents without damage. These requirements are satisfied by making the connection as physically short and direct as possible and using a large diameter wire or braid.

Note that earthing in this context is more about defining a central point

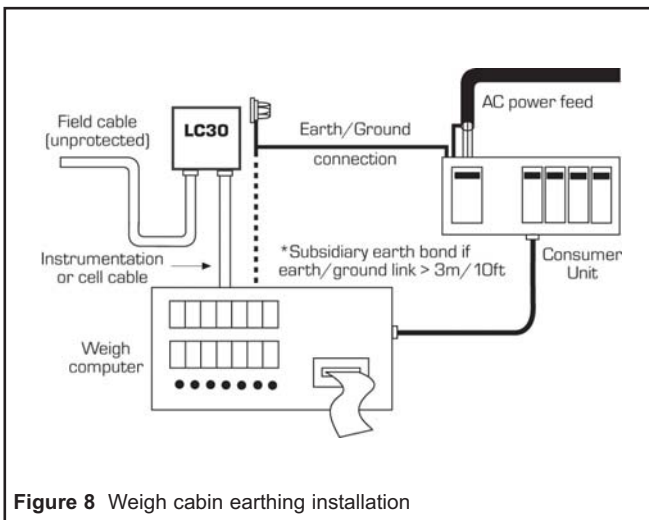

Figure 8 Weigh cabin earthing installation

to which all electrical systems are bonded than about the quality and size of earth mats. Transient voltages are temporary and relative, hence, as long as all systems float up together, no damage can be caused and the systems will return to normal through natural charge dissipation.

Correct bonding at the load cell is shown in figure 7. By bonding the SPD and load cell together, they both rise to the same potential and the load cell is not subjected to additional common mode voltage. No additional ground rods or mats need to be installed.

A typical earthing arrangement within a weigh cabin is illustrated by figure 8. This links an LC30 to the earth point of the incoming ac power feed at the distribution board. This bond is expected to be short, usually less than 3m in length. If the bond needs to be longer than this, a subsidiary link between the LC30 earth stud and the weigh computer is recommended.

Some manufacturers recommend the use of insulating plates between load cells and structural fittings in an attempt to raise the voltage withstand of the load cell. If the insulation level can be maintained, this can provide useful additional systems protection. Unfortunately, the normal installation environment tends to erode the efficiency of the insulation and, during thunderstorms (the time of greatest need), most external installations will be wet, thereby exposing the load cell to the local ground potential and

nullifying the effectiveness of the insulating plate. Therefore, the use of insulating plates as a protection against lightning damage is not recommended.

5 MISCELLANEOUS ASPECTS

5.1 Hazardous-area applications

There are a variety of internationally accepted methods for preventing safe-area electrical faults causing sparks or 'hot-spots' in hazardous areas with all the attendant dangers of potential ignition of flammable atmospheres. The most popular types of protection for low-energy weighing systems in hazardous areas are 'intrinsic safety' (Ex i) or 'non-incendive' (Ex n). However, very rarely, 'flameproof/explosionproof' (Ex d) methods may be used instead.

The LC30 SPD is not inherently 'flameproof/explosionproof' and cannot therefore be used in installations protected by this method unless it itself is mechanically protected by an Exd housing or moved into an adjacent Zone 2 location (Div 2 in North America). However, for intrinsically safe installations the LC30 can be considered as 'simple apparatus' (see section 5.1.1) and 'non-incendive' for Zone 2 installations (see 5.1.2) and hence needs no further certification for these instances.

5.1.1 Intrinsically safe installations

All items in an intrinsically safe (IS) loop must either be certified as 'intrinsically safe' or be classifiable as 'simple apparatus' (i.e. be apparatus which generates or stores $\leq 1.5V$, $\leq 0.1A$ or $\leq 25mW$ under normal or fault conditions). This definition is accepted by most international standards and, in practice, it applies to thermocouples, RTDs, switches, and LEDs amongst other non-energy-storing devices. Although load cells are, by their very nature, examples of simple apparatus and therefore do not need certification, many systems suppliers have obtained certification for their load cells – possibly because load cells are sealed and it is therefore difficult to check the non-energy-storing status on site.

CENELEC standard EN 50 039 2.3 permits the user/contractor to prepare documentation for uncertified IS systems where a knowledge of the physical and electrical parameters '... permit the unambiguous deduction that safety is preserved'. The LC30 has no inductance or capacitance associated with it and so has no effect on the system cable parameters. It is a simple non-energy-storing, non-voltage-producing device (consisting mainly of diodes, resistors and gas discharge tubes) and therefore qualifies as 'simple apparatus'. It must be identified as such and so described on loop interconnection drawings.

Earthing for IS circuits always seems to be made more complicated than necessary - the intention of the standards and codes of practice being to guarantee reliable and robust earthing. North American and European codes are, however, different. In North America, multiple earthing points are permissible on the grounds that IS safety barriers will not conduct at the potential differences normally likely to be encountered between different parts of a process plant. Current European practice, however, insists that an intrinsically safe circuit can only be earthed at one point in the IS loop and that elsewhere the circuit should be capable of withstanding a 500Vrms insulation test, a test that SPDs designed to divert overvoltages and surge currents to earth are inherently incapable of meeting.

The European practice is intended to prevent the inadvertent admission of uncontrolled fault currents from other circuits into the restricted environment of an intrinsically safe loop. However, the presence of SPDs in an IS loop creates a preferential breakdown path for undefined and potentially even more dangerous transient overvoltages. These devices cannot support circulating currents unless there is a high standing potential difference between the local and remote 'earths'; therefore, it can be argued that SPDs enhance the safety of the overall installation by preventing flashover at uncontrolled locations and incorporating them into IS loops is therefore fully justified. See Application Note TAN1004 for further guidance on hazardous-area documentation.

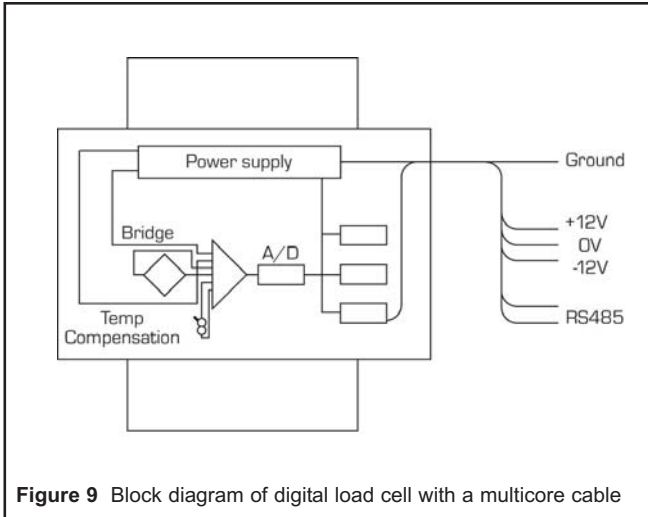

Figure 9 Block diagram of digital load cell with a multicore cable

5.1.2 Zone 2 installations

'Non-incendive' designs provide protection by mechanical construction features which prevent hot spots and ignition-capable sparks developing during normal operation. The LC30 has no exposed sparking contacts (GDTs are sealed devices) and normal weighing measurement circuits cannot produce a working system with hot spots

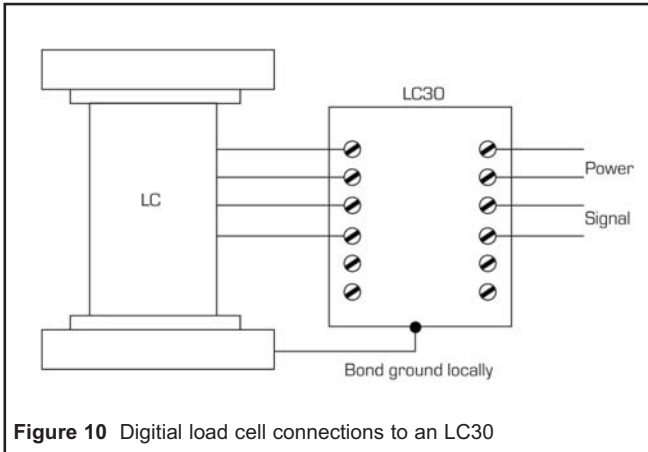

Figure 10 Digital load cell connections to an LC30

on the board. The casing meets the requirements of weatherproof protection to IP54 and the European impact withstand requirement of 7Nm, thereby making the device acceptable for incorporation into a non-incendive loop in a Zone 2 hazardous area. As for IS applications, the loop interconnection drawing should describe and identify the device.

5.2 Digital load cells

In a digital load cell, the A/D converter is included inside the load cell and all the strain-gauge bridge power and temperature conversion is performed locally, so that external cabling effects are eliminated. Figure 9 is a block diagram of the interior of a typical digital load cell. Overall accuracy should be improved and installation should be much easier since corner correction and bridge adjustments can be stored on EPROMs inside the individual cells. The electronic design needed to achieve these features is relatively straightforward and digital cells are likely therefore to eventually displace analogue systems in which the digitizing process takes place in the weigh computer.

Digital load cells are still vulnerable to surge damage along the power feed wiring and the data communication cable as is the weighing computer at the other end of the line. The LC30 can be used with digital load cells for which the supply does not exceed $\pm 15V$. Note that the digital data connections should be made through the voltage sense terminals rather than the (mV) signal terminals, otherwise signal attenuation and possible damage to the LC30 may be caused. Figure 10 details the necessary connections.

5.3 Overall systems considerations

More connections than simply the ones from the load cell are likely to be made to the weighing computer – and these may need surge protection with SPDs other than the LC30. Mains ac power supplies to the computer are generally made from the local distribution board – Telematic and Atlantic Scientific manufacture several SPDs suitable for protecting power supplies from 5A filter/surge protectors for individual line protection to <100A devices suitable for protecting 3-phase feed supplies to the entire cabin. Following the cardinal rule, local protection is better than a single SPD at the 3-phase transformer feeding all site loads. In addition, the smaller individual line filter/protectors will certainly improve system resistance to noise or interference picked up from site load switching, conveyors, motors, etc. Local printers within the weigh cabin are rarely at risk although any links to external printers, data links or modem connections to remote computers, etc. will need protection. Other Application Notes detailed at the front of this document cover devices suitable for these other applications.

5.4 Legal Metrology

The LC30 has been tested and certified in accordance with EN45501 paragraph 8.1 (which is derived from OIML Recommendation R76) by NMI (Nederlands Meetinstituut) for use on non-automated weighing systems and can be used for legal metrology on systems using R60 approved loadcells. Test results demonstrating complete system accuracy in accordance with OIML R60 can be provided on request.

5.4.1 Requirements for legal metrology in the U.K.

The National Weights and Measures Laboratory (NWML) position as regards the inclusion of the LC30 device into systems with an existing pattern approval is as follows:

- a) The load cell should have a respective OIML Certificate of Conformity (R60) or a test certificate (EN45501) issued by a Notified Body responsible for type examination under Directive 90/384/EEC.
- b) The system should have the following characteristics:
 - minimum load cell impedance of $55\ \Omega$
 - maximum excitation voltage of 20V ac or 28V dc
 - excitation voltage is symmetrical to ground
 - for the indicator: $e \geq 1\ \mu V$

The LC30 may be fitted to systems already covered by an existing approval if an amendment to the approval to include the surge protection device is obtained (an application should be made to include the LC30 in each particular pattern). As merely a 'paperwork' exercise, only minimal work, and hence cost, is involved. For new pattern approvals, the Telematic LC30 device can be included at the applicants request, if the characteristics listed above in points a) and b) are satisfied.

If the LC30 device is fitted to installed systems that have already been verified, then the system will have to be re-verified by Trading Standards.

For weighbridge systems that utilise load cells that do not have a respective OIML Certificate of Conformity (R60) or a test certificate (EN45501) issued by a Notified Body (responsible for type examination under Directive 90/384/EEC) the LC30 may be fitted to systems with the above listed characteristics. If the LC30 devices are fitted to installed systems that have already been verified, then the system is to be re-calibrated and then verified by Trading Standards.

MTL Surge Technologies.... Protecting Investments Worldwide

For further information contact your local MTL office or visit
www.mtlsurge.com

Europe, Middle East & Africa

The MTL Instruments Group plc Measurement Technology Limited Escapeline Limited

Power Court, Luton, Bedfordshire
England LU1 3JJ
Tel: +44 (0)1582 723633 Fax: +44 (0)1582 422283
Email: enquiry@mtl-inst.com

MTL Instruments sarl

Les Carrés du Parc
10 rue des Rosiéristes
69410 Champagne au Mont d'Or
France
Tel: +33 (0)4 78 64 98 32 Fax: +33 (0)4 78 35 79 41
Email: info@mtl-inst.fr

MTL Instruments GmbH

An der Gumpgesbrücke 17, D-41564 Kaarst,
Germany
Tel: +49 (0)2131 718930
Fax: +49 (0)2131 7189333
Email: info@mtl.de

MTL Italia srl

Via Cantù 11, 1-20092 Cinisello Balsamo
MI, Italy
Tel: +39 (0)2 61802011 Fax: +39 (0)2 61294560
Email: info@mtl-inst.it

MTL Instruments BV

de Houtakker 33, 6681 CW Bommel, The
Netherlands
Tel: +31 (0)481 450250 Fax: +31 (0)481 450260
Email: info@mtlbenelux.com

MTL Instruments

Abu Dhabi Mall, The Towers at the Trade Centre
West Wing - 8th Floor
PO Box 53234, Abu Dhabi, UAE
Tel: +971 2 645 2620 Fax: +971 2 645 2630
Email: mtlgulf@mtl-inst.com

The Americas

MTL Incorporated

9 Merrill Industrial Drive,
Hampton, NH 03842, USA
Tel: +1 800 835 7075, +1 603 926 0090
Fax: +1 603 926 1899
Email: info@mtlinh.com

MTL Canada Safety Instrumentation

#102, 4249 97 Street
Edmonton, Alberta
Canada T6E 5Y7
Tel: +1 780 485 3132
Fax: +1 780 485 3122
Email: cinfo@mtlinh.com

Asia

MTL Instruments Pte Limited

31 Ubi Road
#04-01 Aztech Building
Singapore 408694
Tel: +65 6 487 7887 Fax: +65 6 487 7997
Email: sales@mtlsing.com.sg

MTL Instruments KK

3rd Floor, Gotanda Masujima Building,
1-8-13 Higashi-Gotanda, Shinagawa-Ku,
Tokyo 141-0022, Japan
Tel: +81 (0)3 5420 1281 Fax: +81 (0)3 5420 2405
Email: sales@mtlkk.co.jp

MTL Instruments Pty Limited

1/30 Canvale Road
Canning Vale, Perth,
WA 6155, Australia
Tel: +61 (0)8 9455 2994 Fax: +61 (0)8 9455 2805
Email: enquiries@mtlaus.com.au

MTL Instruments Pte Limited

Room 1002A, The Gateway,
No. 10 Yaobao Road, Chaoyang District,
Beijing, 100020 People's Republic of China
Tel: +86 10 65915718/20/21
Fax: +86 10 65915725
Email: bjsales@mtl-inst.cn

MTL India Pvt Limited

No. 36, Nehru Street,
Off Old Mahabalipuram Road,
Sholinganallur
Chennai - 600 119
India
Tel: +91 (0)44 2450 1660/2450 1857
Fax: +91 (0)44 2450 1463
Email: sales@mtlindia.com

MTL Surge Technologies

Power Court, Luton, Bedfordshire, England LU1 3JJ
Tel: +44 (0)1582 723633 Fax: +44 (0)1582 422283
E-mail: enquiry@mtlsurge.com WWW: www.mtlsurge.com

A member of the MTL Instruments Group plc

