

MTL Surge Technologies

Surge protection for intrinsically safe systems

Synopsis

This publication discusses the nature of the threat to intrinsically safe instrumentation in hazardous areas from voltage surges induced by lightning or other causes. The practical application of surge protection devices (SPDs) is also considered taking into account the certification/approvals requirements.

Application Note TAN 1004

Application Notes from MTL Surge Technologies

MTL Surge Technologies publish an increasing number of Application Notes providing easily understood information on various aspects of lightning and surge protection. At the date of publication of this Application Note, the list included:-

- TAN1001** Lightning surge protection for electronic equipment – *a practical guide*
A relatively brief and easy to understand introduction to the subject – an excellent starting point.
- TAN1002** Lightning and surge protection – *basic principles*
A more detailed account of the mechanism of lightning strikes and the measures needed to achieve an adequate level of protection.
- TAN1003** Earthing guide for surge protection
A detailed analysis of the subject of earthing for surge suppression purposes, this is both an easily understood exposition and a valuable reference document.
- TAN1004** Surge protection for intrinsically safe systems
A description of the best methods of combining surge protection and intrinsically safe systems.
- TAN1005** Surge protection for Zone O locations
A detailed analysis of this particular aspect of surge suppression in hazardous areas; complements TAN1004.
- TAN1006** Surge protection for weighing systems
Discusses, in some detail, the application of surge suppression to load-cell weighing systems.
- TAN1007** Surge protection for Local Area Networks
Discusses ways in which Local Area Networks can be damaged by lightning induced transients and how they can be protected economically.
- TAN1009** Surge protection for electrical power installations
Discusses aspects of how to protect and install mains devices, with information on earthing and mains systems. A guide to simple maintenance techniques for surge protection devices is included.
- TAN1010** Lightning & surge protection for fieldbus systems
Discusses the major aspects of a fieldbus system and the surge protection required to ensure its smooth running and reliability.

About MTL Surge Technologies

MTL Surge Technologies, the surge protection division of the MTL Instruments Group Plc, designs and manufactures a vast range of protection solutions for all your system surge protection requirements. Comprised of two independent but closely linked companies, Telematic and Atlantic Scientific Corporation, MTL Surge Technologies has a combined experience of nearly 50 years within the surge protection industry.

The MTL Instruments Group has a strong and well respected presence within the Industrial Process market. This, combined with Telematic's close association with the Water Industry and Atlantic Scientific's presence in the Networks and Wireless Infrastructure market, means that MTL Surge Technologies is well placed to support a wide range of industries around the world.

MTL Surge Technologies supplies a comprehensive range of Telematic and Atlantic Scientific surge protection devices offering solutions for all mains power, process control, network and communications, telecom, wireless and RF systems.

Our commitment to not only meet but surpass our customers' high expectations can only be achieved by maintaining very high standards in all aspects of our business. Independent verification of our quality and safety procedures is of paramount importance and our accreditation to internationally recognised standards such as ISO 9001 is proof of this commitment. Our new 10 year 'no fuss' product warranty is even further evidence of our confidence in our products and their application capabilities.

CONTENTS

| | PAGE |
|---|----------|
| 1 | |
| INTRODUCTION..... | 1 |
| 1.1 General..... | 1 |
| 1.2 The need for surge protection | 1 |
| 2 | |
| INTRINSICALLY SAFE SYSTEMS | 1 |
| 2.1 Introduction | 1 |
| 2.2 Intrinsically safe SPDs | 1 |
| 2.3 'Simple apparatus' | 1 |
| 2.4 Design considerations for SPDs in IS circuits | 1 |
| 3 | |
| EARTHING IN IS APPLICATIONS | 2 |
| 3.1 Introduction | 2 |
| 3.2 Earthing in IS circuits equipped with galvanic isolating interfaces | 2 |
| 3.3 Earthing in IS circuits equipped with shunt-diode safety barriers | 2 |
| 3.4 Earthing with SPDs located at both ends of an IS loop | 3 |
| 4 | |
| MISCELLANEDUS ASPECTS | 3 |
| 4.1 Power supply voltage limitations | 3 |
| 4.2 Zone O - special considerations | 5 |
| 4.3 Overall system considerations | 5 |
| APPENDIX: 'SIMPLE APPARATUS' | 5 |

SURGE PROTECTION FOR INTRINSICALLY SAFE SYSTEMS

1 INTRODUCTION

1.1 General

Electronic systems used on process plants or telemetry/monitoring networks associated with these are always at risk from surges and transients caused by power faults or nearby lightning strikes. These transients are just as likely to affect systems located in or connected to hazardous areas as those in safe areas. However, the certification and approvals needed before electrical and electronic systems can be used in potentially explosive atmospheres makes the application of surge protection a little more complicated. This Application Note describes the interaction of surge protection devices (SPDs) with certified and approved intrinsically safe systems for hazardous areas.

1.2 The need for surge protection

Surge protection is needed because modern electronic systems rely on high performance electronic components. However, design considerations for modern systems include faster operation, smaller and cheaper components and lower power consumption; factors which also impair their ability to dissipate any significant impressed energy, so increasing their vulnerability to induced overvoltages and surge currents.

The requirements of systems integrity in hazardous locations are often more stringent than in other locations. For example, emergency shutdown systems are designed to cope with failures in equipment and power supplies – often using duplicated or triplicated sensors, interface cards, processors and even actuators. These systems are generally connected to process sensors by cables which are potential entry routes for surges and transients. Surge protection devices (SPDs) are therefore designed to improve the resilience of such systems to induced transients.

One aspect of surge protection not always appreciated is that an SPD operates locally, i.e. it protects only that part of a loop provided with common grounding. Typically, an SPD mounted at the back of a panel will protect systems within the panel; but, if the field devices also need protecting, this must be done with additional SPDs at the field device locations.

2 INTRINSICALLY SAFE SYSTEMS

2.1 Introduction

Ignition of a potentially explosive atmosphere can be prevented by limiting the available electrical energy to levels below which ignition can take place. Intrinsically safe systems achieve this by one or both of two methods. One method intersperses energy limiting interfaces (such as shunt-diode safety barriers or galvanic isolators) at the safe-area end of each loop while the other makes use, wherever possible, of hazardous-area devices designed to neither store nor generate sufficient energy to cause ignition. The combination of approved hazardous and safe-area devices has proved extremely successful in instrumentation and control applications. Figure 1 illustrates the basic design of an intrinsically safe (IS) loop.

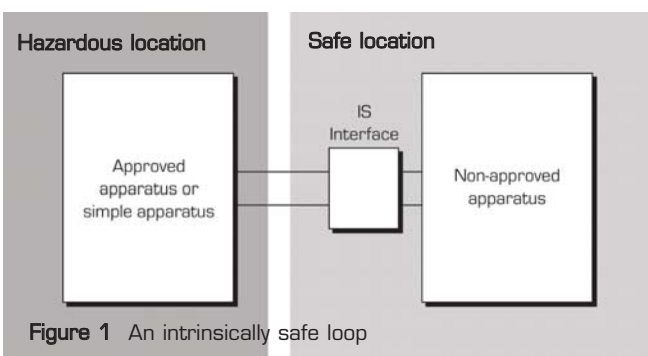

2.2 Intrinsically safe SPDs

Surge protection devices in intrinsically safe circuits must meet the same standards of design and construction as the intrinsically safe equipment, i.e. they must either be considered to be 'simple apparatus' with respect to the performance of energy-storing or voltage-generating components or must be certified as being within the safety parameters of the intended application.

A typical hybrid surge protection device consisting of a gas-discharge tube arrester, series impedance and surge diode, or based on a metal oxide varistor (MOV); is 'simple apparatus' (see 2.3) as permitted on IS interface control drawings and therefore is acceptable for use in IS applications. Alternatively, SPDs may be submitted for independent approval by one of the many national and international test houses.

Some users require all equipment used in intrinsically safe systems to be certified, even items which are demonstrably 'simple apparatus'.

2.3 'Simple apparatus'

A definition of 'simple apparatus' used by the IEC and CENELEC standards for many years is:-

Devices in which, according to the manufacturers specifications, none of the values 1.5V, 0.1A or 25mW is exceeded.

This clause is being moved into the intrinsic safety apparatus standard (IEC and CENELEC) with a much more complete explanation – see the appendix for details. In the US, the equivalent definition is 'non-energy storing, non-voltage producing'.

The widespread use of this clause to cover such things as switches, thermocouples, RTDs, LEDs, etc. is one of the main reasons for the acceptance of intrinsically safe systems. Most Telematic SPDs designed for low-voltage dc systems are 'simple apparatus' and can therefore be added to intrinsically safe circuits without affecting their safety or certification status. Additionally, those frequently used in hazardous areas are third-party certified as equivalent to 'simple apparatus' for those users requiring such documentation.

2.4 Design considerations for SPDs in IS circuits

The design considerations for SPDs is relatively 'open-ended' – there being many possible circuit options - and it is not always clear just how 'simple' a design actually is; inductors may be used to minimize loop resistance and capacitance is often added to provide noise filtering – generally without considering the potential energy-storing effects of such components. It is therefore advisable to use approved or certified SPDs although non-approved SPDs can be used if enough information is provided by the manufacturer to allow the user to establish clear 'simple apparatus' credentials.

It is important to note that SPDs are NOT intrinsically safe interfaces in their own right – even though they may appear to share mechanical or electrical similarities or an obvious common parentage. (Telematic, for instance, is part of The MTL Instruments Group plc, the core company of which is a leading supplier of IS interfaces; and the two companies use similar 'packaging' for key product ranges.) However, although a 'certified' or 'approved' SPD can be included in an intrinsically safe loop, the circuit must also include an intrinsically safe interface of one type or another.

SPDs can be inserted into any part of an IS loop between the IS interface and a field device. In the safe area, it is a common practice to locate them at the back of the panel. SPDs are usually capable of directly terminating field wiring and the safe-area SPD rack is often therefore the starting point for DCS I/O marshalling. Telematic and Atlantic Scientific supply several ranges of SPDs suitable for IS applications including the MTL377 Series and the latest SD Series. For convenience, these devices match the packaging and mounting characteristics of the MTL700 Series and MTL7000 Series of MTL IS safety barriers respectively, although, of course, the SPDs can also be used with IS interfaces from manufacturers other than MTL.

In the safe area, SPDs and IS interfaces should be mounted close to each other but separately – even when the mounting hardware is the

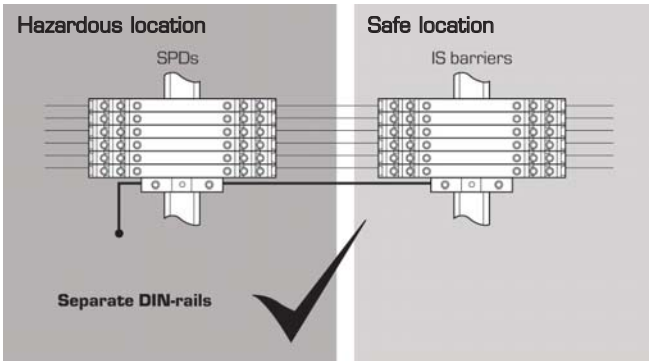
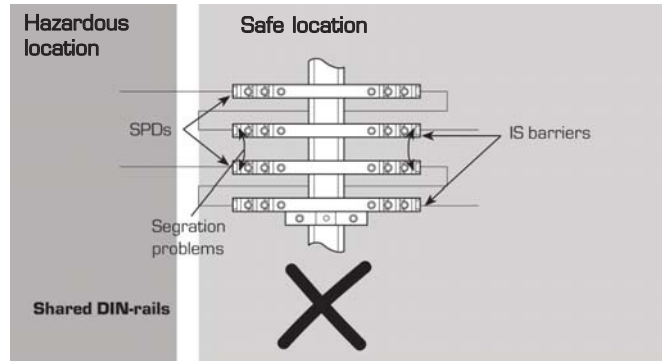

Figure 2 Mounting SPDs and IS interfaces



same. For example, Telematic SD Series SPDs and MTL7000 Series barriers should be mounted on separate DIN-rails (as shown on the left side in figure 2) and NOT on the same DIN-rail (as shown on the right) – this is because there is a requirement for a 50mm clearance between safe-area and hazardous-area terminals and the intertwining of the connections to the devices creates confusion.

In the hazardous area, SPDs can be mounted in weatherproof enclosures to protect a number of field devices associated with one local area, or, more commonly, individual process transmitters can be provided with individual surge protection devices. Most transmitter manufacturers provide surge protection as an optional extra – this typically being provided by an MOV or surge diode component strung between the input terminals. This is rarely effective and should either be replaced or augmented by a separate SPD such as the Telematic TP48. This incorporates a full hybrid circuit (GDT and semiconductor) and can be fitted to any transmitter with a spare conduit entry port. It incorporates a high level of protection with a uniquely practical design concept for easy attachment to the transmitter case (see figure 3). Note that there are various versions of the TP48 for different applications, all of which look alike and it is therefore essential to check that the identification for any individual unit is appropriate for the purpose. TP48-*I indicates intrinsic safety and TP48-*D indicates flameproof; the * indicates the thread type and can be N (for 1/2" NPT), I (for 20mm ISO), P (for Pg13.5) or G (for G 1/2" - BSP 1/2 inch).

3 EARTHING IN IS APPLICATIONS

3.1 Introduction

Earthing/grounding in intrinsically safe systems is often (mistakenly) thought to be very difficult. However, the basic rules are reasonably simple (see MTL Application Note AN9003) and incorporating SPDs into IS circuits makes little difference. What extra needs must be considered are dependent upon the type of IS interface used by the circuit and also the location of SPDs. See:-

- a) Section 3.2 Earthing in IS circuits equipped with galvanic isolating interfaces
- b) Section 3.3 Earthing in IS circuits equipped with shunt-diode safety barriers
- c) Section 3.4 Earthing with SPDs located at both ends of an IS loop

3.2 Earthing in IS circuits equipped with galvanic isolating interfaces

Galvanically isolated IS interfaces do not normally need a high-integrity earth connection – so the SPD earth can be provided as recommended by the SPD manufacturer. If the isolator is being used with a sensor that is also grounded, the earthing considerations are as for a system with SPDs at both ends of a loop (see section 3.4).

3.3 Earthing in IS circuits equipped with shunt-diode safety barriers

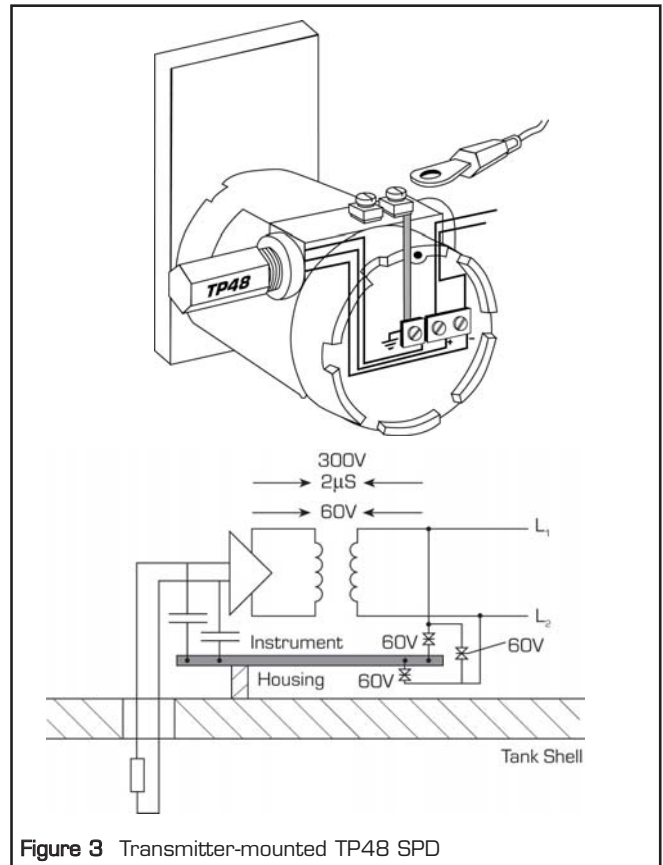

Figure 3 Transmitter-mounted TP48 SPD

Safety barriers must be connected to the main electrical system earth or potential equalizing system with a dedicated conductor of at least 4mm² cross sectional area (12AWG) and a total connection resistance not exceeding 1. SPDs also need effective earthing and there is no conflict between the two requirements – installing an intrinsically-safe system based on safety barriers compels the designer to consider earthing in reasonable detail which generally means it is relatively easy to take account of SPD earthing at the same time.

The best method is to mount the barriers and the SPDs in parallel as shown in figure 2. Figure 4 illustrates a complete IS system showing ideal earthing arrangements for both barriers and SPDs. (In this example both the barriers and the SPDs are shown earthed through DIN-rails – but they can equally well be earthed through busbars or by other reliable means).

In figure 4, the IS earth route is C to G₁ and the SPD earth route E to G₂. The functions of individual components are:-

- a) A-B maintains control system OV/PSU common at the IS earth potential.
- b) C-D maintains the IS ground at the SPD earth potential and provides the first link in the IS earth bond.
- c) E-F terminates the SPD earth at the main electrical

system earth bar and can be tied to a local lightning ground mat at G_2 (if one is installed) as well as being part of the IS bond.

Typically, the SPD earth connection will be made with an 8 to 10AWG wire, leading to a very low connection resistance for E-F, typically less than 0.5 . The overall IS bond, C- G_1 is therefore less than 1 and better than 12AWG. Earth wiring should be labelled distinctly to deter unauthorised removal and should be made with reliable connectors.

Provided these requirements are followed, the needs of both IS and SPD earthing are satisfied without compromise.

Note that the usual link between the control system and the main electrical earth should be removed. If present, it acts as a parallel path to earth through which excess current through the SPDs can be routed back into the system I/O, precisely the consequence the SPDs are fitted to prevent! Some system installers insist on maintaining this link, in which case it is best provided through a large inductor/coil such that under normal operating conditions a dc connection exists but which provides an inductive impedance against fast rise-time transients which diverts them back to the SPD earth path. This coil is sometimes augmented by a gas-discharge tube (GDT) connected in parallel. However, the actual contribution of the GDT is little understood and it may simply be 'black magic'.

3.4 Earthing with SPDs located at both ends of an IS loop

If surge protection is applied to both ends of an intrinsically safe loop, there are two indirect circuit earths – indirect in the sense that SPDs only earth lines through surge diodes/gas-tube arrestors or MOVs. Requirements for intrinsic safety installations usually specify circuits capable of withstanding a 500V insulation test to earth throughout the loop except at one nominated point, usually the safety barrier. If the sensor connection is also earthed, galvanic isolators are usually specified. Because of the way they operate, SPDs cannot withstand a 500V insulation test - hence installing SPDs at both ends of a loop represents a deviation from recommended IS installation practice.

Individual countries have differing views on the effect of multiple earths. In the UK, potential equalizing conductors (4mm² minimum conductors between the two earth points) have often been specified as shown in figure 5. German practice is similar in principle, except that the common bonding is made to the plant potential equalization network. In the USA, multiple earths are permitted, though users are cautioned about possible earth loop interference problems.

Telematic's view, expressed through the IEC working group on harmonization of installation practices, is that the SPD acts as a deliberate and controlled breakdown path capable of repeated operation without degradation under severe stress. In preventing open (hazardous) sparkover at some other uncontrolled point,

SPDs make the installation safer. If 10kA surges or 10kV transients are being transmitted round the plant, it is better to control them with respect to local plant earth in a predictable and reliable manner than to permit random flashover at uncontrolled points.

4 MISCELLANEOUS ASPECTS

4.1 Power supply voltage limitations

A requirement for intrinsically safe certification is the necessity to limit the 'normal' power supply voltage (U_m), usually to 250V rms or dc, to define the maximum stress that can be applied to the protection components, diodes and fuses. Some applications are potentially exposed to higher ac power supply voltages, e.g. some delta ac supplies, and systems including CRTs and other high voltage devices. Suitable SPDs can be installed on the safe-area side of IS interfaces to prevent the interfaces being subjected to voltages higher than their U_m rating.

The protection of mining machinery is an example. Sensors tied to the coal-face (hazardous area) are preferably IS for ease of replacement and use but the power supply to the hydraulic systems within the machinery is 500V dc. Fitting separate isolation transformers for the sensors and instrumentation is prohibitively expensive – making SPDs the ideal economic choice to guarantee that under fault conditions the IS interfaces are not exposed to the full 500V dc supply or to significant transients from other sources that are potential hazards.

4.2 Zone 0 – special considerations

The draft IEC Code of Practice requires that circuits which cross boundaries between Zone 0 and Zone 1 and which may be subjected to significant voltage transients are bonded at the crossing points to eliminate the possibility of Zone 0 being invaded by lightning or stray fault currents. In figure 6, an isolating interface connected to a Zone 0 sensor experiences a temporary voltage differential caused by a nearby lightning strike. Flashover between the high local earth and the remotely earthed or floating sensor wiring inside Zone 0 is likely to be hazardous – similar events are believed to have caused many fires, particularly in oil storage tank farms. Installing an SPD at the Zone 0 boundary prevents flashover in this most hazardous part of the circuit.

This does not however, protect the loop isolator which is still exposed to the high transient voltage and may well be damaged or destroyed. A second SPD is recommended at that point (shown dotted in figure 6). While the loss of one isolator may not itself be a direct cause of ignition, consequential damage in the DCS or ESD system may well lead to a dangerous plant condition and prove expensive, either directly or through a spurious plant shutdown.

This particular application is covered in much greater detail in TAN1005.

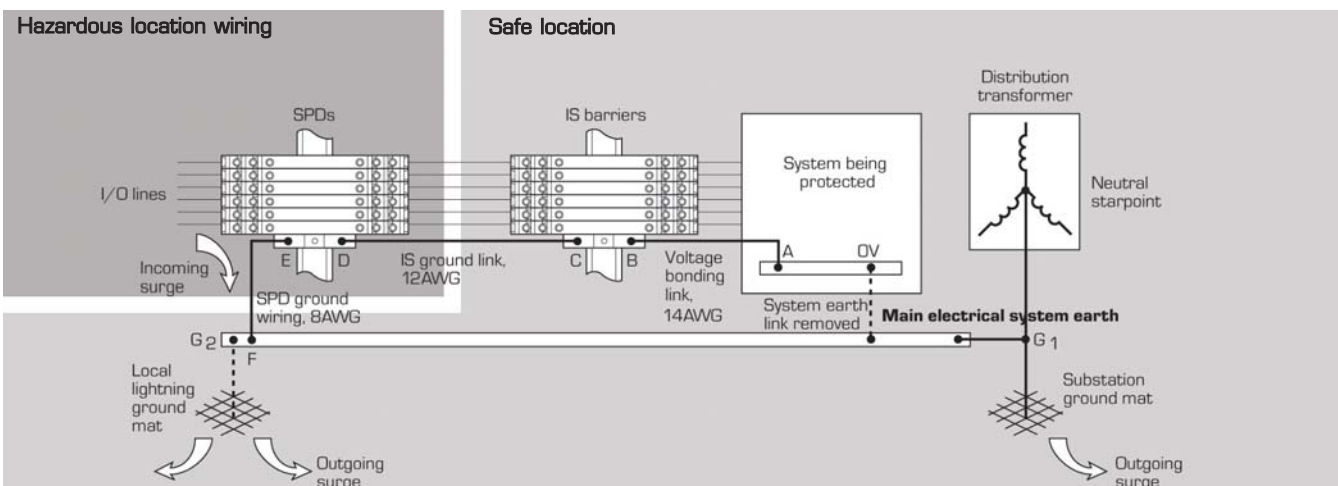

Figure 4 Recommended earthing system for loops including IS barriers and SPDs

Hazardous location

Safe location

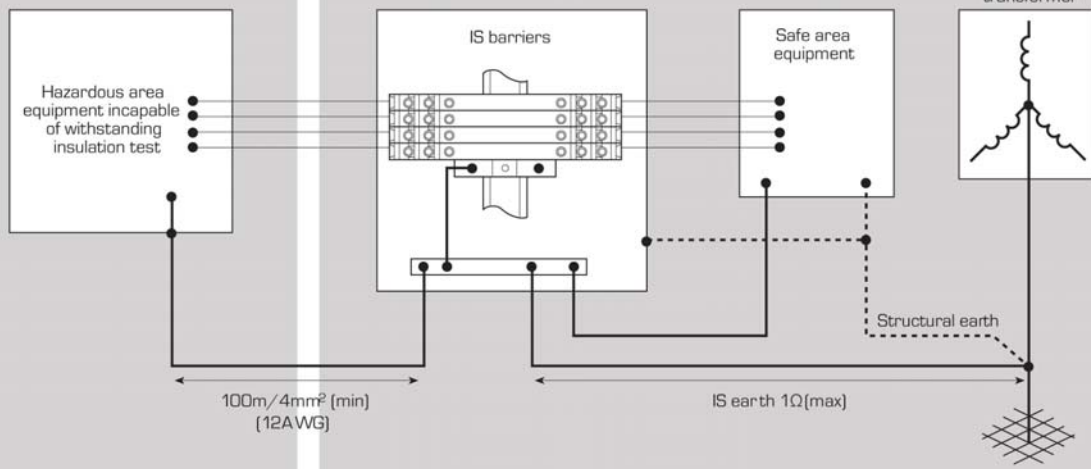

Figure 5 Potential equalizing conductors - UK practice

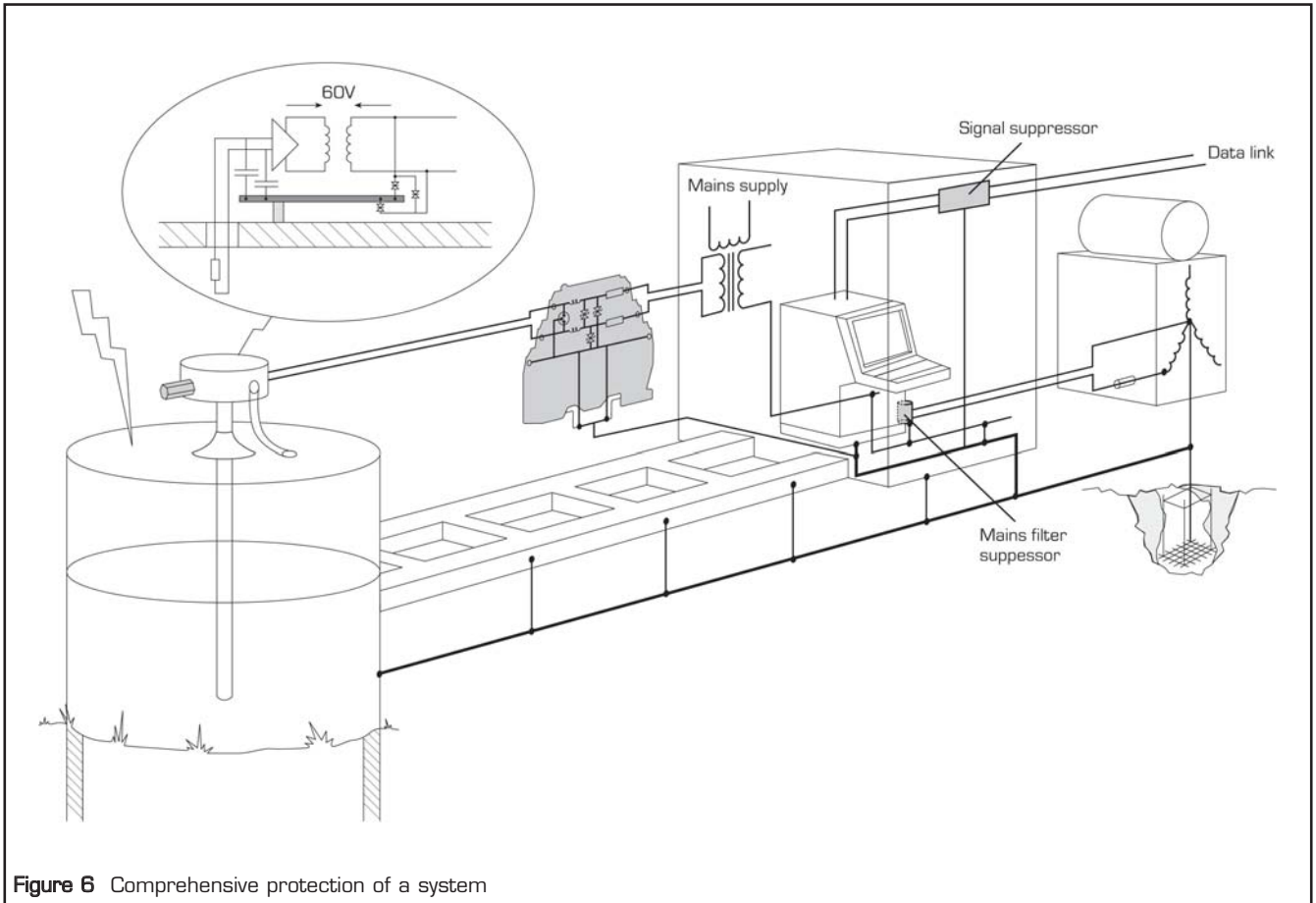

Figure 6 Comprehensive protection of a system

4.3 Overall system considerations

The system documentation should indicate what form of protection is used on each loop. Where certified or approved SPDs are used, certificates should be collated or (in North America) entity parameters established and appropriately referenced on the installation drawings. If uncertified or non-approved SPDs are used, it is normally sufficient to provide a common reference document – detailing the reasons why the chosen SPDs are considered safe for that application – signed by a competent authority.

Process control systems (DCS, ESD, etc.) are likely to include additional connections to other devices or systems such as local area networks, telephone modems and, of course, ac power supplies. The surge protection process is not complete until all cabled connections into and out of protected systems have, at least, been considered. Figure 6 illustrates a comprehensive solution for a typical installation.

APPENDIX: 'SIMPLE APPARATUS'

The following requirements for simple apparatus are extracted from EN50020: 1995. The references in bold are to sections of the standard not reproduced here.

5.4 Simple apparatus

The following apparatus shall be considered to be simple apparatus:-

- a) Passive components, e.g. switches, junction boxes, potentiometers and simple semi-conductor devices;
- b) Sources of stored energy with well-defined parameters, e.g. capacitors or inductors, whose values shall be considered when determining the overall safety of the system;

- c) Sources of generated energy, e.g. thermocouples and photocells, which do not generate more than 1.5V, 100mA and 25mW. Any inductance or capacitance present in these sources of energy shall be considered as in b).

Simple apparatus shall conform to all relevant requirements of this standard but need not be certified and need not comply with **clause 12**. In particular the following aspects shall always be considered.

- 1) Simple apparatus shall not achieve safety by the inclusion of voltage and/or current limiting and/or suppression devices.
- 2) Simple apparatus shall not contain any means of increasing the available voltage or current, e.g. circuits for the generation of ancillary power supplies.
- 3) Where it is necessary that the simple apparatus maintains the integrity of the isolation from 'earth' of the intrinsically-safe circuit, it shall be capable of withstanding the test voltage to earth in accordance with **6.4.12**. Its terminals shall conform to **6.3.1**.
- 4) Non-metallic enclosures and enclosures containing light metals when located in the hazardous area shall conform to **7.3** and **8.1 of EN50014**.
- 5) When simple apparatus is located in the hazardous area it shall be temperature classified. When used in an intrinsically safe circuit within their normal rating switches, plugs and sockets and terminals are allocated a T6 temperature classification for Group II applications and considered as having a maximum surface temperature of 85°C for Group I applications. Other types of simple apparatus shall be temperature classified in accordance with clause **4 and 6** of this standard.

Where simple apparatus forms part of an apparatus containing other electrical circuits the whole shall be certified.

MTL Surge Technologies.... Protecting Investments Worldwide

For further information contact your local MTL office or visit
www.mtlsurge.com

Europe, Middle East & Africa

The MTL Instruments Group plc Measurement Technology Limited

Escapeline Limited
Power Court, Luton, Bedfordshire
England LU1 3JJ
Tel: +44 (0)1582 723633 Fax: +44 (0)1582 422283
Email: enquiry@mtl-inst.com

MTL Instruments sarl

Les Carrés du Parc
10 rue des Rosiéristes
69410 Champagne au Mont d'Or
France
Tel: +33 (0)4 78 64 98 32 Fax: +33 (0)4 78 35 79 41
Email: info@mtl-inst.fr

MTL Instruments GmbH

An der Gumpesbrücke 17, D-41564 Kaarst,
Germany
Tel: +49 (0)2131 718930
Fax: +49 (0)2131 7189333
Email: info@mtl.de

MTL Italia srl

Via Cantù 11, 1-20092 Cinisello Balsamo
MI, Italy
Tel: +39 (0)2 61802011 Fax: +39 (0)2 61294560
Email: info@mtl-inst.it

MTL Instruments BV

de Houtakker 33, 6681 CW Bommel, The
Netherlands
Tel: +31 (0)481 450250 Fax: +31 (0)481 450260
Email: info@mtlbenelux.com

MTL Instruments

Abu Dhabi Mall, The Towers at the Trade Centre
West Wing - 8th Floor
PO Box 53234, Abu Dhabi, UAE
Tel: +971 2 645 2620 Fax: +971 2 645 2630
Email: mtlgulf@mtl-inst.com

The Americas

MTL Incorporated

9 Merrill Industrial Drive,
Hampton, NH 03842, USA
Tel: +1 800 835 7075, +1 603 926 0090
Fax: +1 603 926 1899
Email: info@mtlnh.com

MTL Canada Safety Instrumentation

#102, 4249 97 Street
Edmonton, Alberta
Canada T6E 5Y7
Tel: +1 780 485 3132
Fax: +1 780 485 3122
Email: cinfo@mtlnh.com

Asia

MTL Instruments Pte Limited

31 Ubi Road
#04-01 Aztech Building
Singapore 408694
Tel: +65 6 487 7887 Fax: +65 6 487 7997
Email: sales@mtlsing.com.sg

MTL Instruments KK

3rd Floor, Gotanda Masujima Building,
1-8-13 Higashi-Gotanda, Shinagawa-Ku,
Tokyo 141-0022, Japan
Tel: +81 (0)3 5420 1281 Fax: +81 (0)3 5420 2405
Email: sales@mtlkk.co.jp

MTL Instruments Pty Limited

1/30 Canvale Road
Canning Vale, Perth,
WA 6155, Australia
Tel: +61 (0)8 9455 2994 Fax: +61 (0)8 9455 2805
Email: enquiries@mtlaus.com.au

MTL Instruments Pte Limited

Room 1002A, The Gateway,
No. 10 Yaobao Road, Chaoyang District,
Beijing, 100020 People's Republic of China
Tel: +86 10 65915718/20/21
Fax: +86 10 65915725
Email: bjsales@mtl-inst.cn

MTL India Pvt Limited

No. 36, Nehru Street,
Off Old Mahabalipuram Road,
Sholinganallur
Chennai - 600 119
India
Tel: +91 (0)44 2450 1660/2450 1857
Fax: +91 (0)44 2450 1463
Email: sales@mtlindia.com

MTL Surge Technologies

Power Court, Luton, Beds, UK LU1 3JJ
Tel: +44 (0)1582 723633 Fax: +44 (0)1582 422283
E-mail: enquiry@mtlsurge.com WWW: www.mtlsurge.com

A member of the MTL Instruments Group plc

